

element[®] e12

Fiber-Coupled Semiconductor Laser

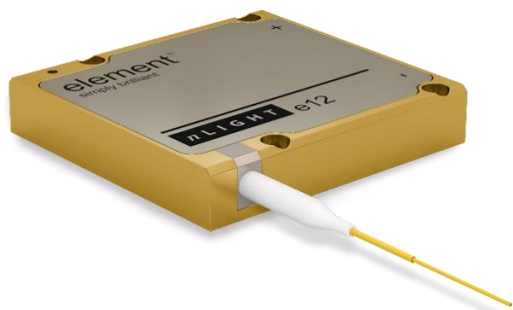

90W, 793nm, 200μm

Item Number : 1087905

	Unit	Minimum	Typical	Maximum
Optical Specifications				
CW Output Power (in fiber) ⁴	W	83	90	
Wavelength Centroid	nm	790.0	793.0	796.0
Spectral Width (FWHM)	nm		1.9	4.0
NA within 95% Power Enclosure	-		0.14	
Fiber Core / Clad Diameter	μm		200 / 220	
Fiber NA / Index Type / Cladding Type	-		0.22 NA / Step Index / Dual Clad	
Back Reflection Isolation 1850 - 2100nm	dB	15		
Electrical Specifications				
Electrical-to-Optical Efficiency	%		42	
Threshold Current	A		1.9	
Operating Current	A		10.0	10.0
Operating Voltage	V		21.2	22.0
Thermal Specifications				
Operating (Housing) Temperature ³	°C		+30	
Storage Temperature ³	°C	-25		70
Wavelength Temperature Coefficient	nm / °C		0.28	
Wavelength Current Coefficient	nm / A		0.5	
Mechanical Specifications				
Mass	g		440	
Fiber Length	m	1.5	2.0	
Active Fiber Bend Radius	mm	35		
Product Information				
Item Description	-	e12-12-090-0793-3-200-0.22-SI-FPT-2.0-HT		
Fiber Jacketing	-	900 μm Hytel Tubing		
Fiber Termination	-	FPT		
Export Control Classification Number (ECCN)	-	EAR99		

Notes

- 1 Product image not necessarily representative of exact appearance.
- 2 Production specifications shown are for beginning of life performance at the typical operating temperature. End of life operating current (Iop) is 110% beginning of life Iop.
- 3 A non-condensing environment with relative humidity between 5 - 85% is required for operation and storage.
- 4 The CW Output Power (in-fiber) specified is 3.5% higher than the as-measured values to account for Fresnel loss that wouldn't be present in the intended spliced use condition.

sales@nlight.net | www.nlight.net

element e12

900 μm Hytrel Tubing Bare fiber pigtail

Item Number : 1087905

Mechanical Drawings

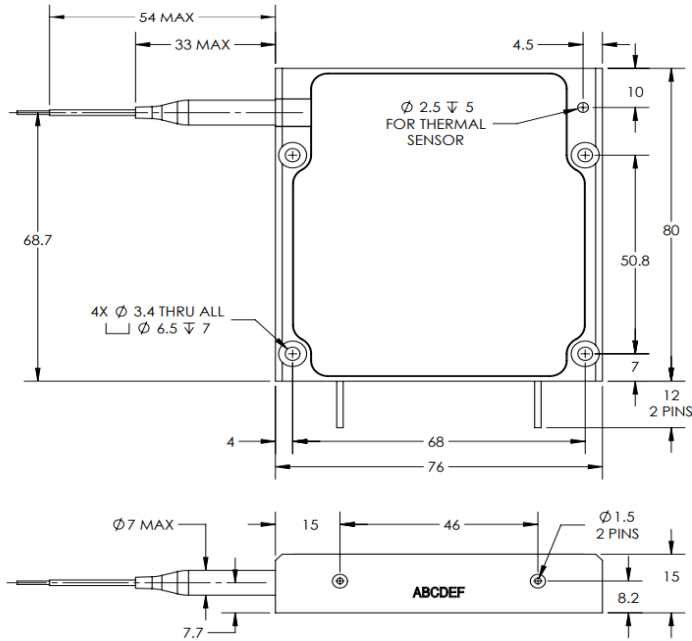

ALL DIMENSIONS IN mm WITH ±0.25mm TOLERANCE.

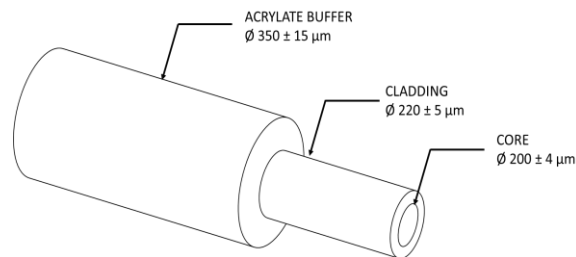
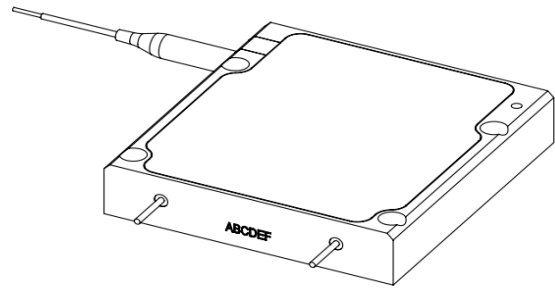

BARE FIBER DRAWING

nLIGHT continually improves its products to provide customers outstanding quality and reliability. The information contained herein is subject to change without notice.

This product is not certified in accordance with IEC 60825-1 or 21CFR1040.10/ 21CFR1040.11 and is solely intended to be integrated into a laser product certified by the Purchaser. The Purchaser acknowledges that their product (incorporating nLIGHT laser product) must comply with the applicable regulations before it can be sold.



sales@nlight.net | www.nlight.net

© nLIGHT, Inc. 2023
Rev 4/5/2023

