

External Cavity Laser 14-pin Butterfly Narrow Linewidth Single-Frequency

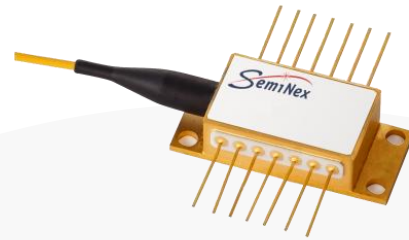

Part Number: 14BF-312

External Cavity Laser
14BF Narrow Linewidth Single-Frequency
CW Wavelength at 1310nm O-Band



Features

- Narrow linewidth (~10 kHz)
- Central wavelength 1310 nm or other O band
- Good wavelength stability
- Low power dissipation
- Ultra-low RIN, excellent SMSR
- **SemiNex ROSA Chip Inside**

Application

- Fiber optical sensing: acoustic & seismic interferometric sensing, Oil & Gas - exploration and production
- LiDAR and industrial metrology
- Optical measurements and instrumentation



SemiNex delivers the highest available power at infrared wavelengths between 12xx and 19xx nm. When necessary, we will further optimize the design of our InP & GaSb laser chips to meet our customers' specific optical and electrical performance needs. Diodes, bars and packages are tested to meet customer and market performance demands. Typical results and packaging options are shown. Contact SemiNex for additional details or to discuss your specific requirements.

External Cavity Laser
 14-pin Butterfly
 Narrow Linewidth Single-Frequency



Specification

14BF-312

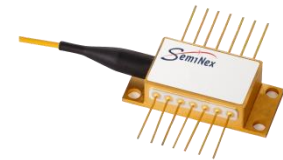

Optical	Symbol	Min.	Typ.	Max.	Units
Center Wavelength	λ_c		1310 or O band		nm
Linewidth (Lorentzian)	FWHM		10		kHz
Fiber Output Power	Pf		10		mW
Side Mode Suppression	SMSR		55		dB
Polarization Extinction Ratio	PER	20			dB
Random Intensity Noise	RIN			-145	dB/Hz
Optical Isolation	ISO		50		dB
Operating Temperature	T _O	-20		60	°C
Storage Temperature	T _s	-40		85	°C
Operating Humidity	%	5		85	

Parameter	Symbol	Min.	Typ.	Max.	Unit
LD Voltage	V _{LD}		1.6	1.8	V
LD Current	I _{LD}		150	300	mA
TEC Voltage	V _{TEC}		1.8	2.5	V
TEC Current	I _{TEC}		1	1.5	A
TEC Temp.	T _{TEC}		25	50	°C

*Specified values are rated at a constant heat sink temperature of 20°C.

**High temperature operation will reduce performance and MTTF.
 Unless otherwise indicated all values are nominal.

High Power Laser Diode 14BF Narrow Linewidth Single-Frequency Laser



SemiNex Laser Diodes 14BF-312 Graphs & Data

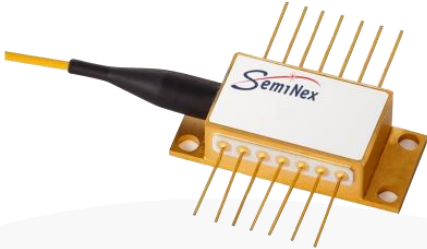

Lorentzian Linewidth (7.86kHz)

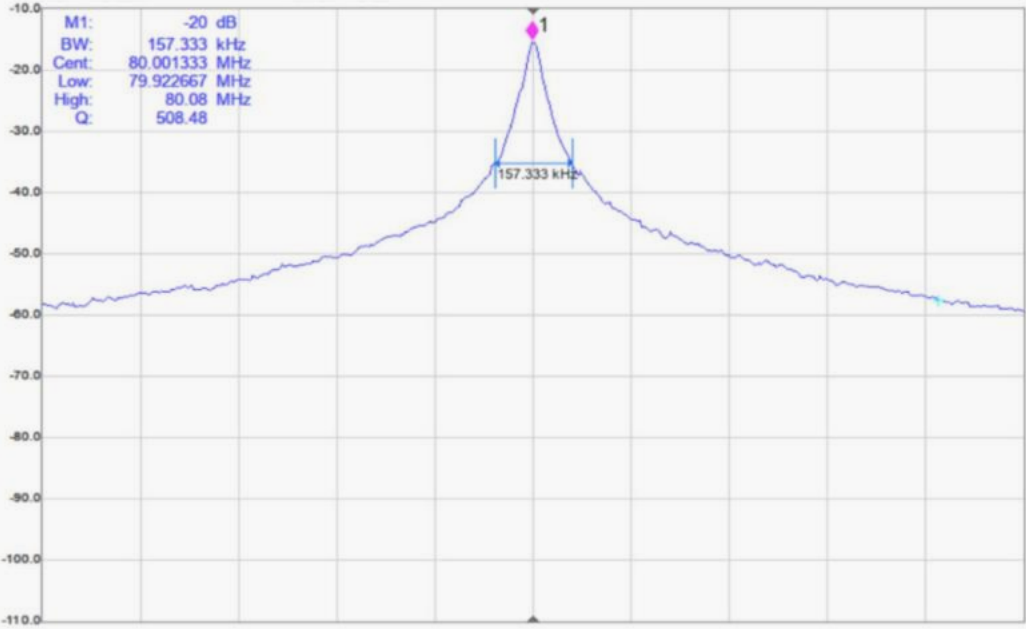

External Cavity Laser 14-pin Butterfly Narrow Linewidth Single-Frequency



Mechanical Drawing

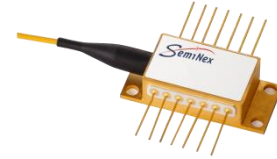

No.	Description	Parameter	Unit	Note
1	Fiber type	PMF ϕ 0.9mm red		PMF/SMF Optional
2	Fiber length	1000 \pm 10	mm	
3	Connector	FC/APC		

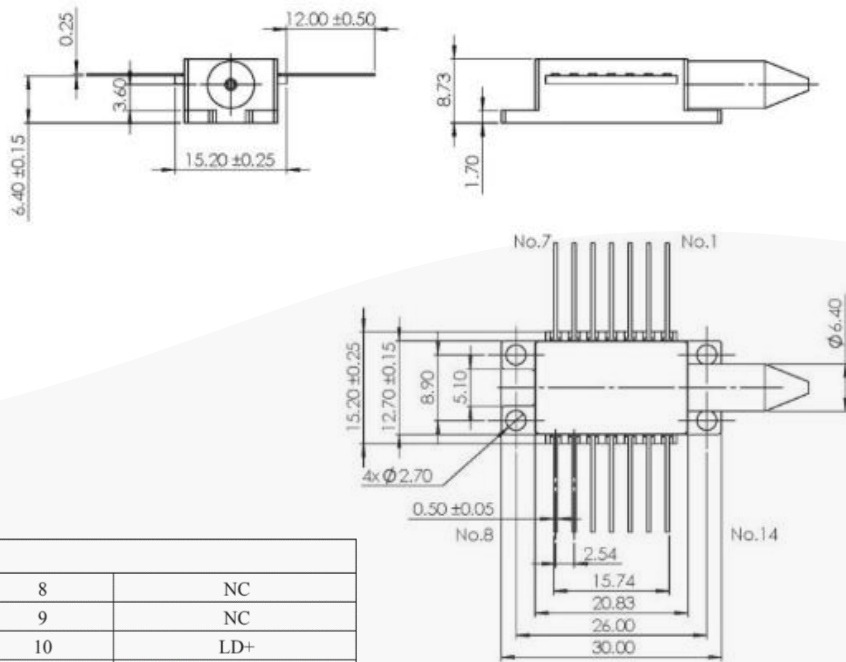

Pinout			
1	TEC +	8	NC
2	Thermistors	9	NC
3	PD -	10	LD+
4	PD +	11	LD-
5	Thermistors	12	NC
6	NC	13	Case
7	NC	14	TEC -

Warnings:
Make sure to wear protective goggles while operating high power laser that could be harmful to eyes. Nearby operators should wear protective goggles to avoid harms from the reflective of the laser. SemiNex reserves the right to modify this document without notice.

All statements, technical information and recommendations related to the product herein are based upon information believed to be reliable or accurate. The accuracy or completeness herein is not guaranteed, and no responsibility is assumed for any inaccuracies. The user assumes all risks and liability whatsoever in connection with the use of a product or its application. SemiNex Corporation reserves the right to change at any time without notice the design, specification, deduction, fit or form of its described herein, including withdrawal at any time of a product offered for sale herein. Users are encouraged to visit www.seminex.com for the latest data. SemiNex Corporation makes no representations that the products herein are free from any intellectual property claims of others. Please contact SemiNex for more information. 2024 SemiNex Corporation

