

Model 442

IR-EYE™ INTEGRATED SENSOR

Parallel Opposed Dual IR Detector With Integrated Signal Processing*



* Patent Pending. Manufactured under one or more of the following U.S. patents: 3,839,640 - 4,218,620 - 4,326,663 - 4,384,207 - 4,437,003 - 4,441,023 - 4,523,095

The **Model 442 IR-EYE™** Integrated Sensor is a lithium tantalate pyroelectric parallel opposed dual element high gain detector with complete integral analog signal processing. This unit offers greatly improved detection capability over an extended temperature range of -40 to +70°C with no significant change in noise or sensitivity and significantly reduced temperature spiking.

Advantages

- Eliminate Burn-In Tests
- Improve RF Immunity
- Eliminate False Alarms
- Simplify Circuitry
- Reduce Component Count
- Improve Reliability

Features

- 100x Signal Amplification
- Stable, Accessible Internal Voltage Reference
- Wide Operating Temperature Range

Applications

- People / Object Detection
- Intrusion Detection
- Lighting Control
- Robotics
- Motion Sensing
- Automatic Door Control
- Safety Warning
- High Stability Industrial & Military Applications

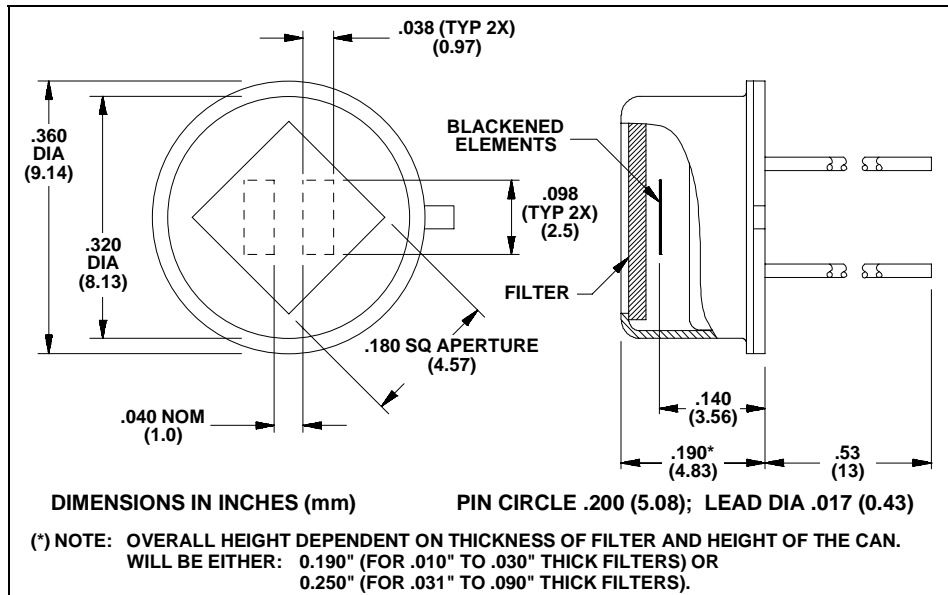

Characteristics	442	Unit	Test Conditions	ELTECdata Reference
Detector Type	POD			
Element Size	1.0 x 2.5	mm, each		
Optical Bandwidth	0.1 to 1,000	μm	Various Filters	101
Responsivity (typ)	3.7×10^5	V/W	8 to 14 μm, 1 Hz	
Noise (typ)	270	μVrms/√Hz	1 Hz, 1 Hz BW	
NEP (typ)	7.3×10^{-10}	W/√Hz	8 to 14 μm, 1 Hz, 1 Hz BW	100
D* (typ)	2.2×10^8	cm√Hz/W	8 to 14 μm, 1 Hz, 1 Hz BW	100
Common Mode Rejection Ratio (min) (typ)	5/1 (15/1)		8 to 14 μm, 1 Hz	
Operating Voltage (min) (max)	5 (15)	VDC	V+ to Gnd	104 (4.1.c)
Operating Current (max)	2.2	mA		104 (4.1.c)
Offset Voltage	± 500	mV	Referenced to Pin 3	106 Section B
Reference Voltage ¹	+2.50 ± .08	V		
Thermal Breakpoint f _T (typ)	.20	Hz		102
Recommended Operating Temperature	-40 to +70	°C	Functional	
Storage Temperature	-55 to +125	°C	ΔT < 50°C/min	
Output Load (min)	10k	Ω		
Output Protection	Short circuit protected, but DO NOT REVERSE SUPPLY POLARITY			

Characteristics at 25°C, with -3 filter, V+ = 5VDC

Data is established on a sample basis and is believed to be representative.

¹The internal reference voltage is accessible on Pin 3. This voltage is used to bias the internal amplifier. Offset voltage is referred to this point. This voltage provides a low drift reference to allow for direct DC coupling of a subsequent comparator or A/D converter. The recommended maximum load on this pin is 100 μA (source only) to maintain electrical and thermal stability. Current loads greater than 100 μA may adversely affect performance; however, the output is short circuit protected.

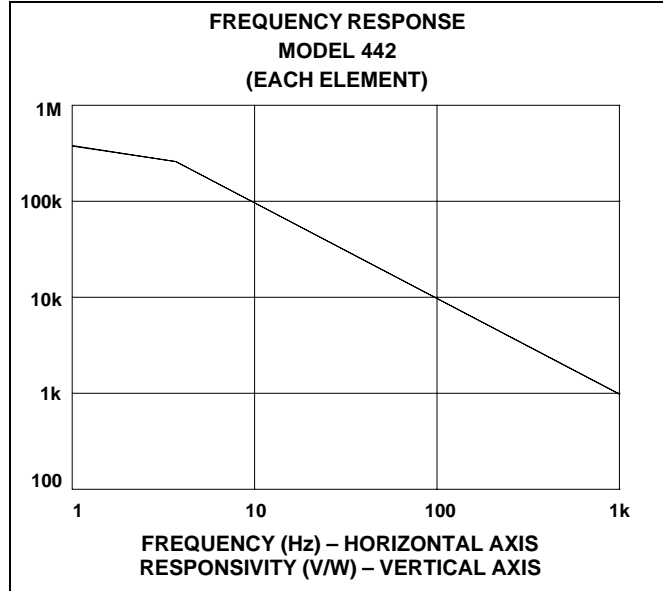
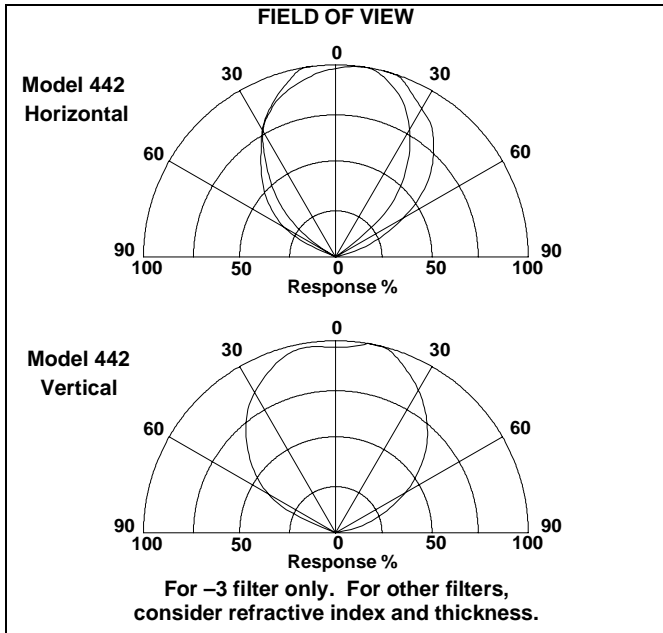

For best results, the following precautions and recommendations should be observed. (See ELTECdata #101):

Mounting: Avoid mechanical stresses on case and leads.

Soldering: Detectors must be hand soldered to minimize the chance of destroying the internal components. Avoid machine or hot air soldering. Leave a minimum lead length of .250 inch (6.35mm). When soldering to detector leads, use a heat sink between the case and leads. Beware that the new RoHS compliant solders require a higher soldering temperature making heat sinking the detector extremely important.

Static Discharge: Protect detectors from electro-static charges.

Thermal Shock: Temperature changes and rate of change must be kept to a minimum (<50C°/min.) to prevent damage.

Noise: As a resolution or lower information limit, noise is established not only by the detector. Other noise sources are:

- Radiated and conducted RF signals
- Subsequent amplification or signal conditioning stages
- Power supply noise
- Components, such as high value resistors and capacitors (tantalum and aluminum electrolytic)
- Mechanical contacts and weak solder joints
- Shock and vibration excited microphonics
- Outside thermal influences on the detector other than the desired infrared input, i.e. drafts

All of these noise sources should be considered carefully when the information signal is <10 mV.

Light Leakage: Slight sensitivity to visible light leaking through the glass-to-metal seal on the base may be observed.

Optical Design: Use of a detector with a filter in an optical system may require consideration of the image displacement toward the filter. This displacement (s) caused by the insertion of a planoparallel plate (filter thickness = t; refractive index = N) is given by $s = (t/N)(N-1)$.

NOTICE: The information provided herein is believed to be reliable. However, ELTEC Instruments, Inc. assumes no responsibility for inaccuracies or omissions. Due to industry components being incorporated into ELTEC's devices and ELTEC continually striving for product improvement, specifications may change without notice.

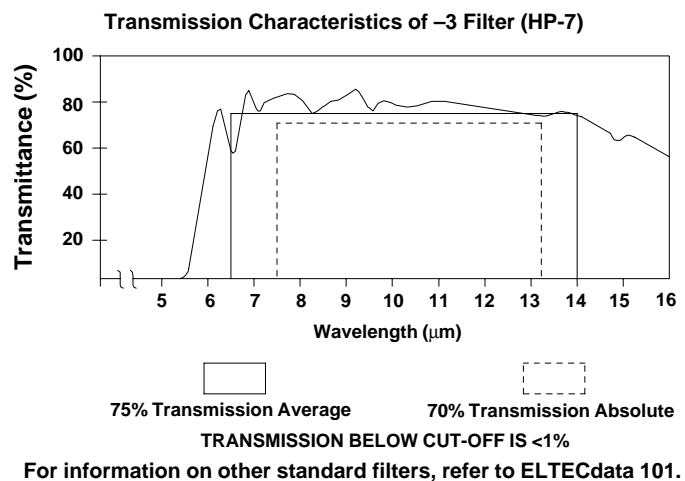
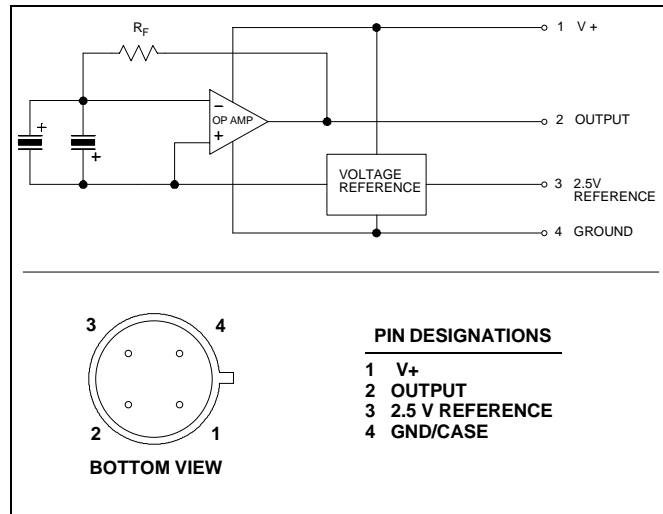

silverlight^S

Worldwide Product Distribution and Technical Support:
Silverlight Ltd., CH-Winterthur, Switzerland
info@silverlight.ch www.silverlight.ch