



Single-mode & Polarization-stable VCSEL

850 nm, TO46,
2.0 mW



> Ideal circular
Gaussian beam

> Stable
polarization

> Single-mode

Electro-optical characteristics

T = 20°C unless otherwise stated

Parameter	Symbol	Units	Min	Typ	Max	Test conditions
Emission wavelength	λ_R	nm	830		870	$P_{OP} = 2 \text{ mW}$
Threshold current	I_{TH}	mA			2	
Laser current	I_{OP}	mA			6	$P_{opt.} = 2 \text{ mW}$
Laser voltage	U_{OP}	V			2.6	$P_{opt.} = 2 \text{ mW}$
Slope efficiency	η_S	W/A	0.5		1	
Output power	P_{opt}	mW	2	2.5		$I_{OP} = 6 \text{ mA}$
Differential series resistance	R_S	Ω	50		200	$P_{opt.} = 2 \text{ mW}$
Beam divergence	Θ	°	10		20	$P_{opt.} = 2 \text{ mW}$, full width $1/e^2$
Side mode suppression ratio	SMSR	dB	10			$P_{opt.} = 2 \text{ mW}$
ESD damage threshold		V	2000*			human body model
Wavelength tuning over temperature		nm/K		0.06		

*for TO package with integrated Z-diode

Absolute Maximum Ratings

Storage temperatur	-40 to 125°C
Operating temperature	-40 to 85°C
Electrical power dissipation	20 mW
Continuous forward laser current	8 mA
Continuous reverse current	10 mA
Soldering temperature	330°C

NOTICE: Stresses greater than those listed under „Absolute Maximum Ratings“ may cause permanent damage to the device. These are stress ratings only and functional operation of the device at these or any other condition beyond those indicated for extended periods of time may effect device reliability.



ATTENTION: Electrostatic Sensitive Devices
Observe Precautions for Handling

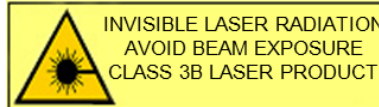

Spectral characteristics

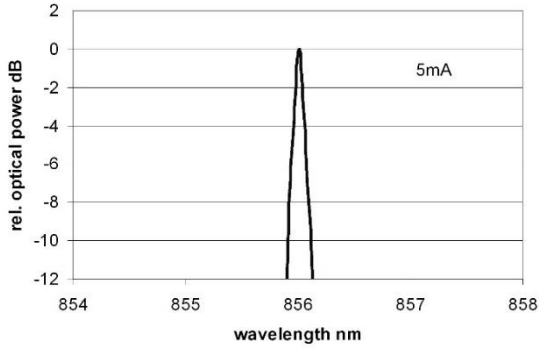
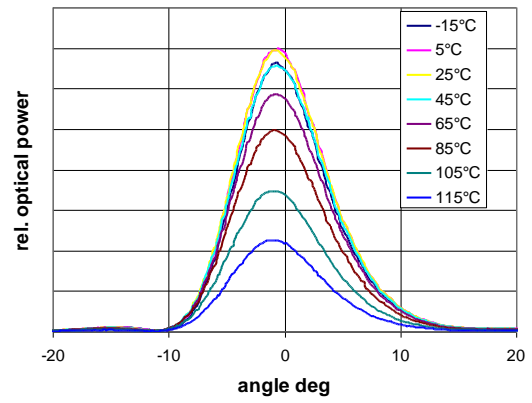
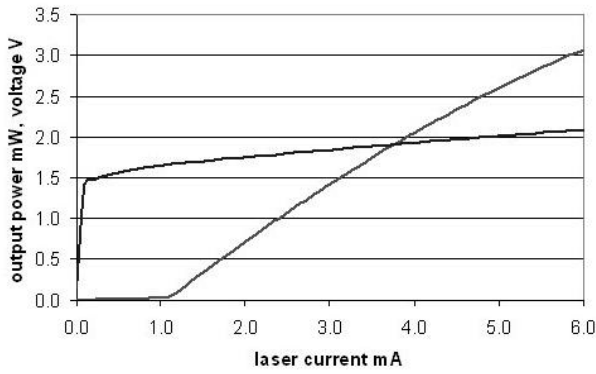

TO dimensions (without TEC)

flat glass window

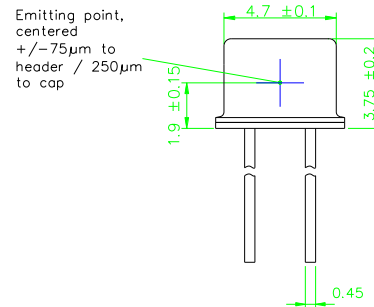

Pin configuration

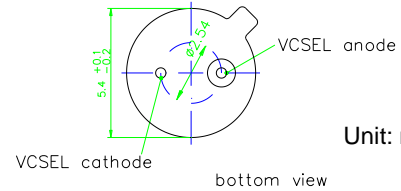

Unit: mm

Die dimensions

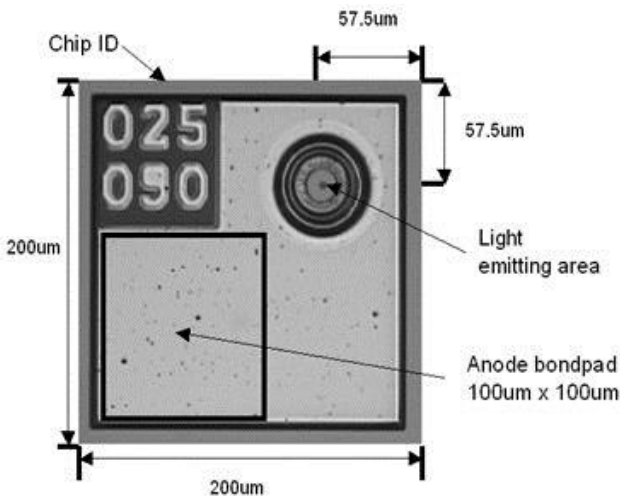

For order please use:

Product Number

ULM850-B2-PL-S0101U
 ULM850-B2-PL-S46FZP
 ULM850-B2-PL-S46FTT

Description

850nm single-mode bare die
 850nm single-mode TO46 glass window
 850nm single-mode TO46 integrated TEC and NTC