

SPC – PSD

High Linearity Position Sensing Detector with Signal Processing Circuit

Part number: S1 – 0271

Description: 1L2,5_SU74_SPC02

The SiTek 1L2,5_SU74_SPC02 is a 1L2,5 PSD with an attached signal processing circuit. The PSD currents are output as bipolar voltages representing the position and intensity of the centroid of a light spot on the PSD. The intensity signal can be used for external normalisation of the position (difference) signal in regard to light intensity dependence. Inputs are available for external adjustment of offset voltages.

In order to obtain maximum precision, high reliability and small size the SPC02 is built using thick film technology and laser trimmed resistors on a 20,5 x 20,5 mm² ceramic substrate. The SPC02 is delivered with DIL pins.

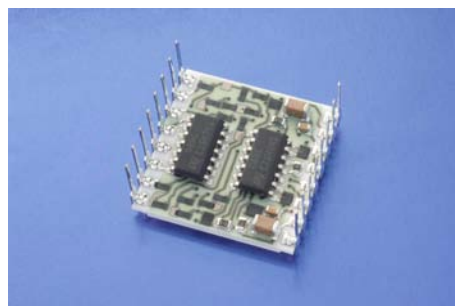
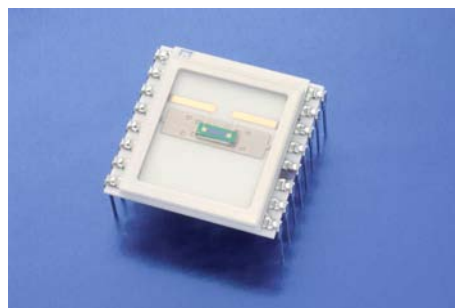

Electrical specification

Parameter	Symbol	Min.	Typ.	Max.	Unit
Active area			2,5 x 0,6		mm ²
Position non-linearity			0,1	0,2	% (±)
Reverse bias	V_r		15		V
Dark current of PSD @ V_r	I_d		2	10	nA
Responsivity	r		63		V/mW
Transimpedance	R_f	$0,999 \cdot 10^5$	$1,000 \cdot 10^5$	$1,001 \cdot 10^5$	V/A
Amplification in sum and difference stages	A_v	0,999	1	1,001	
Output voltage	V_{out}			± 12	V
Output noise	V_{noise}		3		mVp-p
Bandwidth	f_{3dB}		400		kHz
Slew rate	SR	8	13		V/μs
Supply current			12	23	mA

Absolute maximum ratings

Parameter	Symbol	Value	Unit
Power supply voltage	V_s	± 18	V
Output short-circuit time		Continuous	
Operating temperature	T_{oper}	70	°C
Storage temperature	T_{ste}	100	°C

Test conditions:

Room temperature 23 °C, Power supply voltage ± 15 V, Light source wavelength 940 nm. Position non-linearity are valid within 80 % of the detector length.

Package:

16 pin ceramic substrate, 20,5 x 20,5 mm², with protective window.

For further information about PSD specific parameters see specification for S1-0001 1L2,5_CP2.



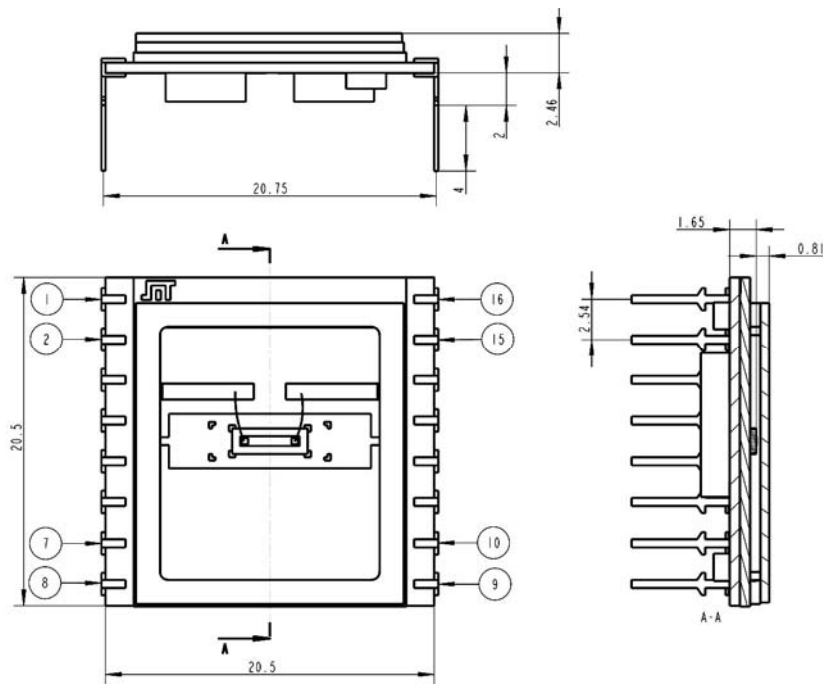

Pin no.	Input/Output
1	Amp Y1
2	N.A.
3	N.A.
4	Sum Y
5	N.A.
6	OA Sum Y
7	N.A.
8	N.A.
9	N.A.
10	+15 V
11	Gnd
12	Gnd
13	Diff Y
14	OA Diff Y
15	-15 V
16	Amp Y2

Please note that all pins not applicable (N.A.) for 1-dimensional devices must be left floating.

Block schematics

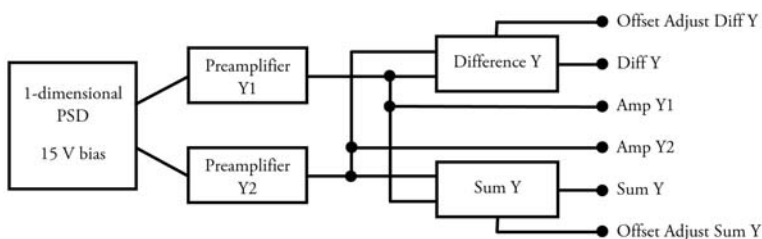

Features

- Analogue outputs of all sum and differential signals
- Laser trimmed resistors
- Inputs for external adjustment of offset voltages
- Good thermal tracking
- Small size

Applications

- Analogue PSD front-end in displacement measuring systems for OEM as well as evaluation purposes.

Application Information

Inputs 6 and 14 are used for external offset compensating voltages. Such a voltage can, as shown in the figure, be derived from a voltage divider and connected to the SPC input through a suitable series resistor.

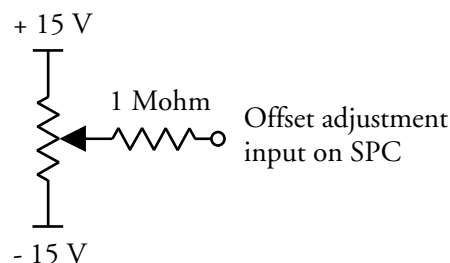

Information in this data sheet is believed to be reliable. However, no responsibility is assumed for possible inaccuracies or omissions. Specifications are subjected to changes without notice.