

## 650nm 10mW 50°C Reliable Operation

### Features

- Output Power : 10mW
- Package :  $\Phi 5.6\text{mm}$
- TE mode
- Single Transverse/Longitudinal Mode
- Stable reliability

### Applications

- Industry : Laser level, illumination, meter, scanner, detector
- Consumer : Point light, sweeper, game lighting
- Health : Special wavelength light source

### Absolute maximum ratings

Parameter	Symbol	Condition	Rating	Unit
Light output power	$P_o$	CW	13	mW
Reverse voltage (LD)	$V_{RL}$	-	2	V
Case temperature	$T_C$	-	-10~+50	°C
Storage temperature	$T_S$	-	-40~+85	°C

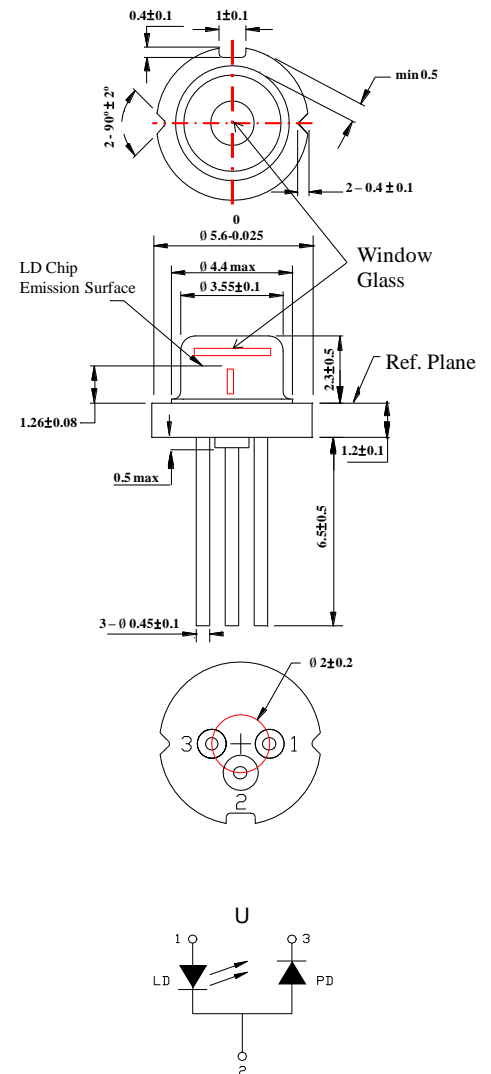

### Electrical and optical characteristics ( $T_c=25^\circ\text{C}$ )

Parameter	Symbol	Min.	Typ.	Max.	Unit	Conditions
Peak wavelength	$\lambda$	645	650	660	nm	$P_o=10\text{mW}$
Threshold current	$I_{th}$	-	20	25	mA	
Operating current	$I_{op}$	-	28	40	mA	$P_o=10\text{mW}$
Operating voltage	$V_{op}$	-	2.2	2.5	V	$P_o=10\text{mW}$
Differential efficiency	$\eta$	0.7	0.9	1.2	mW/mA	$P_o=7\text{-}10\text{mW}$
Monitor current	$I_m$	0.1	0.26	0.4	mA	$P_o=10\text{mW}$ $V_{RD}=5\text{V}$
Parallel divergence angle	$\theta_{//}$	6	9.5	12	deg.	$P_o=10\text{mW}$
Perpendicular divergence angle	$\theta_{\perp}$	25	28	32	deg.	
Parallel FFP deviation angle	$\Delta\theta_{//}$	-2	0	+2	deg.	
Perpendicular FFP deviation angle	$\Delta\theta_{\perp}$	-2	0	+2	deg.	
Emission point accuracy	$\Delta x\Delta y\Delta z$	-80	0	+80	um	

#### ● Precautions

- \* Do not operate the device above maximum ratings. Doing so may cause unexpected and permanent damage to the device.
- \* Take precautions to avoid electrostatic discharge and/or momentary power spikes. A change in the characteristics of the laser or premature failure may result.
- \* Proper heat sinking of the device assures stability and lifetime. Always ensure that maximum operating temperatures are not exceeded.
- \* Observing visible or invisible laser beams with the human eye directly, or indirectly, can cause permanent damage. Use a camera to observe the laser.
- \* No laser device should be used in any application or situation where life or property is at risk in event of device failure.
- \* Specifications are subject to change without notice. Ensure that you have the latest specification by contacting us prior to purchase or use of the product.

## 650nm 10mW 50°C Reliable Operation

