

Characteristics :

- ◆ low cost SiC-photodiode
- ◆ active area: 0,05 mm²
- ◆ spectral range: 210 ... 355 nm
- ◆ high UV-responsivity: 0,16 A/W
- ◆ hermetically sealed TO-package
- ◆ option for isolated assembly of photodiode
- ◆ HT-option for extended operating temperature range 150°C
- ◆ RoHS, REACH and WEEE conform



Applications :

- ◆ optical measurements in UV-range
- ◆ control of sterilization lamps
- ◆ flame control

Absolute Maximum Ratings :

- ◆ reverse voltage 20 V
- ◆ operating temperature range - 40 °C ... 125 °C
- ◆ storage temperature range - 40 °C ... 125 °C
- ◆ soldering temperature (3s) 260 °C

Versions:

Package	Anode: isolated Cathode: Case	Anode: isolated Cathode: Case	Cathode, Anode : isolated + Case-Pin	Operating Temperature up to 150 °C
TO5	JEA0,05	JEAC0,05	JEA0,05I	*-HT
TO18	JEA0,05S	JEAC0,05S	JEA0,05ISZ	
TO52	JEA0,05SS	JEAC0,05SS	JEA0,05ISSZ	

Relativ Spectral Responsivity

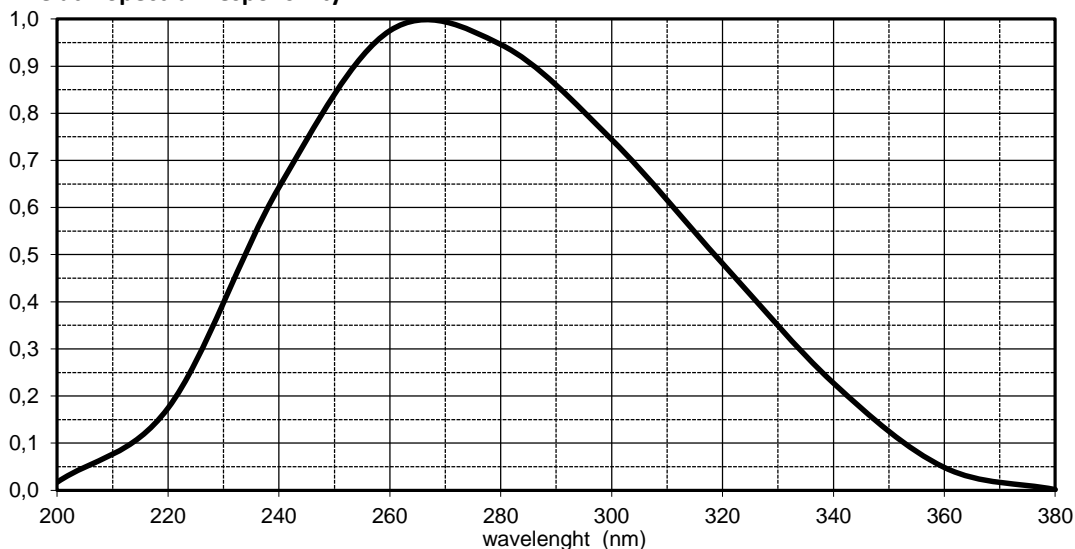

Rev. 1 (08/2017)

Technical Data :

test conditions, as not otherwise specified: $T_A = 25\text{ }^\circ\text{C}$, $V_R = 0\text{ V}$

Parameter	Test condition	JEA0,05	JEA0,05S	JEA0,05SS	Unit
		JEAC0,05 JEA0,05I	JEAC0,05S JEA0,05ISZ	JEAC0,05SS JEA0,05ISSZ	
active area		0,288 x 0,288			mm ²
spectral range	$S = 0,1 \times S_{\max}$				
λ_{\min}		210			nm
λ_{\max}		355			nm
wavelength of peak response		265			nm
peak response S_{\max}	$\lambda = 265\text{ nm}$	0,16			A/W
spectral response $S_{254\text{nm}}$	$\lambda = 254\text{ nm}$	0,144			A/W
dark current I_R	$V_R = 1\text{ V}$	10			fA
junction capacitance C_j	$f = 10\text{ kHz}$	30			pF
field of view (FOV)		±45	±35	±40	degree
FOV for isolated assembly		±48	±38	±45	degree
weight		0,8	0,3	0,3	gram
package drawing for direct/isolated assembly		TO39 / TO39 iso.	TO18 / TO18 iso.	TO52 / TO52 iso.	

Application Example

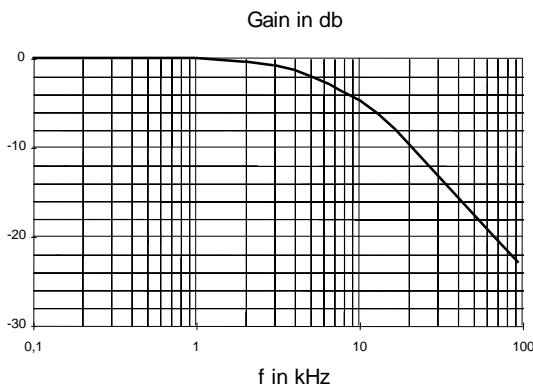
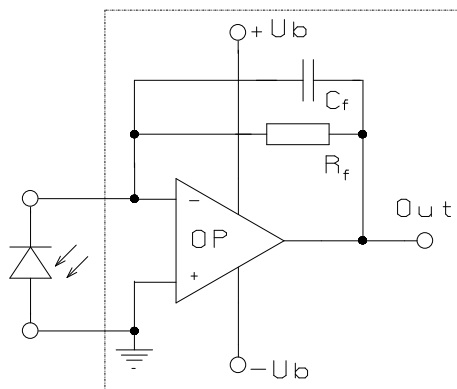

The application example shows a typical circuit R_f is responsible for the gain of the circuit C_f compensates the reverse junction capacitance of the photodiode and the input capacitance of the opamp. The exact value of C_f depends on R_f , used opamp and capacitance of the circuit. A typical value is 1pF.

The chart shows dependence of amplitude of the application circuit with opamp = AD795, $R_f = 10\text{ M}\Omega$ and $C_f = 1\text{ pF}$.

Case Dimensions:

TO39

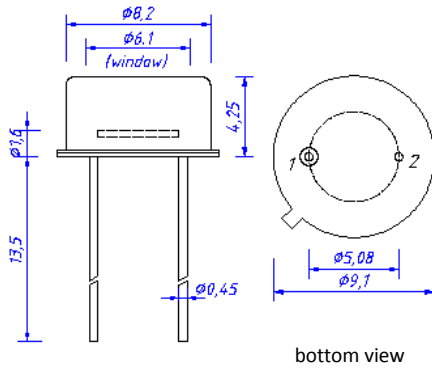

JEA0,05: pin 1: anode
pin 2: cathode + case

JEAC0,05: pin 1: cathode
pin 2: anode + case

TO39 isolated

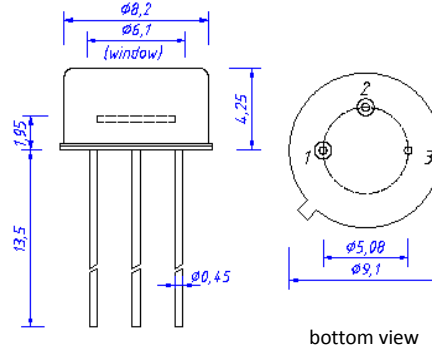

JEA0,05I: pin 1: anode
pin 2: cathode
pin 3: case

TO18 / TO52

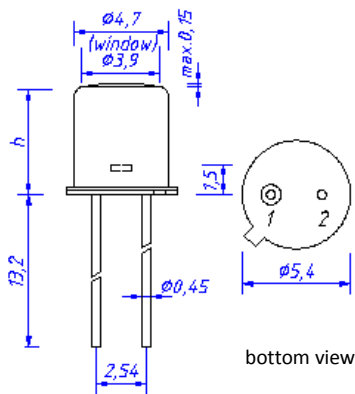

JEA0,05S/SS: pin 1: anode
pin 2: cathode + case

JEAC0,05S/SS: pin 1: cathode
pin 2: anode + case

TO18 isolated / TO52 isolated

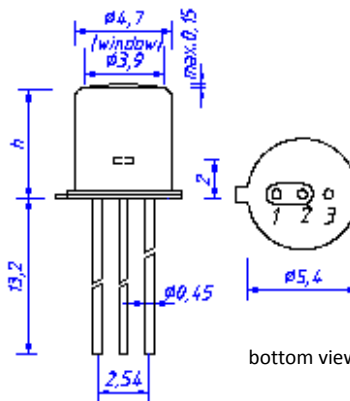

JEA0,05ISZ/JEA0,05ISSZ: pin 1: anode
pin 2: cathode
pin 3: case

TO18: h = 5,2 mm
TO52: h = 3,7 mm