

# Model 406M39

## Single Element Pyroelectric IR Detector with Enhanced Source Follower



Manufactured under one or more of the following U.S. patents: 3,839,640 - 4,218,620 - 4,326,663 - 4,384,207 - 4,437,003 - 4,441,023 - 4,523,095

**Model 406M39** pyroelectric detector incorporates enhanced voltage mode circuitry to provide higher responsivity than traditional source followers. The amount of gain realized is dependent on the value of the external source resistor chosen. Typically, 100k  $\Omega$  provides excellent performance. For applications where a single element detector is indicated, Eltec recommends evaluation of both the 406M39 and 406 units.

Like the Model 406, the Model 406M39 utilizes a 2 mm diameter lithium tantalate crystal mounted with Eltec's patented loop suspension. As regards interfacing, it is recommended that the signal be taken between the source and ground (or artificial ground) rather than with a "common" source circuit.

### Applications

- Motion Sensing
- Lighting Control
- Intrusion Detection
- Industrial Control
- Gas Analysis
- Heating/AC Control
- Pyrometry
- Low-power Laser Detection
- Robotics
- Instrumentation

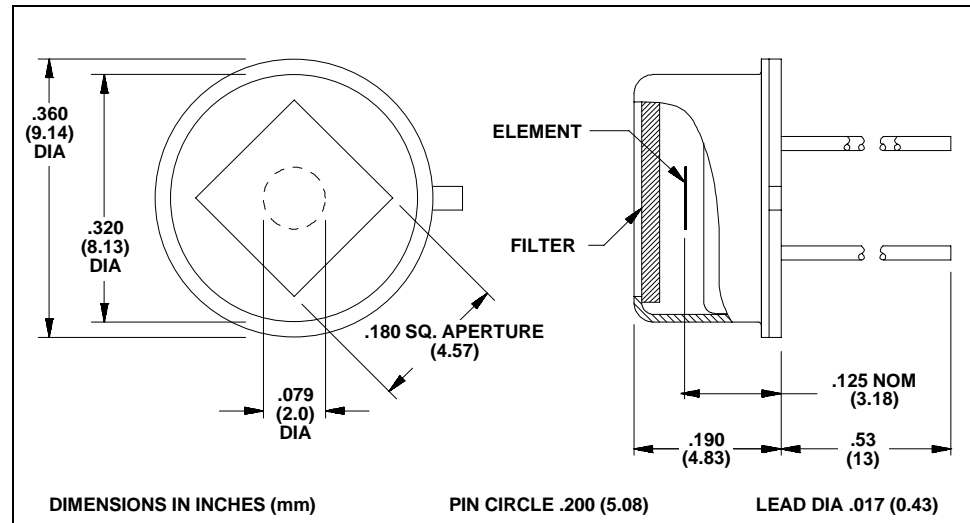

Characteristics	406M39	Unit	Test Conditions	ELTECdata Reference
Detector Type	Single			
Element Size	2.0	mm, dia		
Optical Bandwidth	0.1 to 1,000	$\mu\text{m}$	Various Filters	101
Responsivity (typ)	3,190	V/W	8 to 14 $\mu\text{m}$ , 10 Hz	
Noise (typ)	3.4	$\mu\text{Vrms}/\sqrt{\text{Hz}}$	10 Hz, 1 Hz BW	
NEP (typ)	$1.09 \times 10^{-9}$	$\text{W}/\sqrt{\text{Hz}}$	8 to 14 $\mu\text{m}$ , 10 Hz, 1 Hz BW	100
D* (typ)	$1.72 \times 10^8$	$\text{cm}\sqrt{\text{Hz}}/\text{W}$	8 to 14 $\mu\text{m}$ , 10 Hz, 1 Hz BW	100
Operating Voltage (min)	5	VDC	V+ to Gnd	104
Operating Voltage (max)	10			(4.1.c)
Operating Current (min)	8	$\mu\text{A}$	$R_S = 100\text{k } \Omega$	104
Operating Current (max)	30			(4.1.c)
Offset Voltage (min)	0.8	V	$R_S = 100\text{k } \Omega$	106
Offset Voltage (max)	3.0			Section B
Output Impedance	$<R_S$	$\Omega$		
Thermal Breakpoint $f_T$ (typ)	0.25	Hz		102
Recommended Operating Temperature	-40 to +70	$^{\circ}\text{C}$	Functional	
Storage Temperature	-55 to +125	$^{\circ}\text{C}$	$\Delta T < 50^{\circ}\text{C}/\text{min}$	
Output Protection	Do not exceed a maximum drain current of 2 mA			

Characteristics at: 25 $^{\circ}\text{C}$ , with -3 filter, V+ = 5VDC,  $R_S = 100\text{k } \Omega$  unless otherwise stated. Data is established on a sample basis and is believed to be representative.

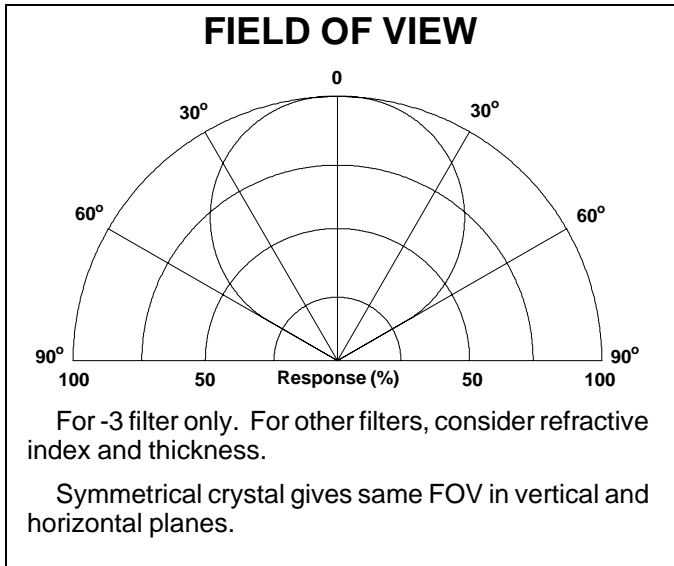

For best results, the following precautions and recommendations should be observed. (See ELTECdata # 101):

**Mounting:** Avoid mechanical stresses on case and leads.

**Soldering:** Detectors must be hand soldered to minimize the chance of destroying the internal components. Avoid machine or hot air soldering. Leave a minimum lead length of .250 inch (6.35mm). When soldering to detector leads, use a heat sink between the case and leads. Beware that the new RoHS compliant solders require a higher soldering temperature making heat sinking the detector extremely important.

**Static Discharge:** Protect detectors from electrostatic charges.

#### Transmission Characteristics of -3 Filter (HP7)

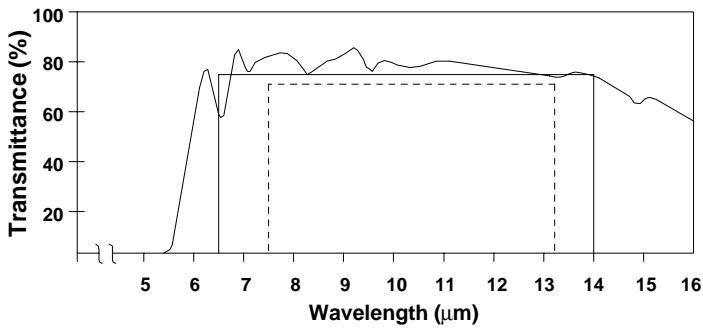

75% Transmission Average

70% Transmission Absolute

Transmission below cutoff is < 1%

For information on other standard filters available, refer to ELTECdata # 101.

**Thermal Shock:** Temperature changes and rate of change must be kept to a minimum (<50C<sup>0</sup>/min.) to prevent damage.

**Noise:** As a resolution or lower information limit, noise is established not only by the detector. Other noise sources are:

- Radiated and conducted RF signals
- Subsequent amplification or signal conditioning stages
- Power supply noise
- Components, such as high value resistors and capacitors (tantalum or electrolytic)
- Mechanical contacts and weak solder joints
- Shock and vibration excited microphonics
- Outside thermal influences on the detector other than the desired infrared input, i.e. drafts

All of these noise sources should be considered carefully when the information signal is <1mV.

**Light Leakage:** Slight sensitivity to visible light leaking through the base glass-to-metal seal may be observed.

**Optical Design:** Use of a detector with a filter in an optical system may require consideration of the image displacement toward the filter. This displacement (s) caused by the insertion of a planoparallel plate (filter thickness = t; refractive index = N) is given by  $s = (t/N) (N-1)$ .

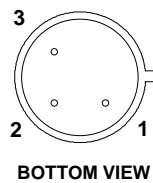
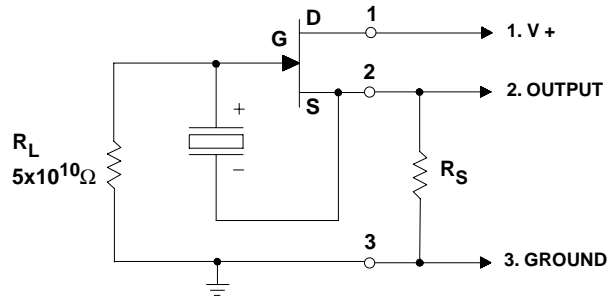

#### PIN DESIGNATIONS

1. V+
2. OUTPUT
3. GND/CASE

**NOTICE:** The information provided herein is believed to be reliable. However, ELTEC Instruments, Inc. assumes no responsibility for inaccuracies or omissions. Due to industry components being incorporated into ELTEC's devices and ELTEC continually striving for product improvement, specifications may change without notice.

**Performance data from production units of the Eltec Model 406M39-3 pyroelectric detectors at 1, 10, 100, and 1,000 Hz modulation.**

UNIT	SENSITIVITY (V)	NOISE (V)	RESPONSIVITY (V/W)	NEP (W/√Hz)	D* (cm√Hz/W)	NOTE
1	8.80E-01	4.2E-06	1.60E+04	8.28E-10	2.14E+08	I
2	8.40E-01	1.2E-06	1.53E+04	2.48E-10	7.15E+08	I
3	1.40E+00	2.6E-06	2.55E+04	3.22E-10	5.50E+08	I
4	1.80E+00	3.6E-06	3.28E+04	3.47E-10	5.11E+08	I
5	7.60E-01	4.2E-06	1.39E+04	9.59E-10	1.85E+08	I
6	5.80E-01	3.4E-06	1.06E+04	1.02E-09	1.74E+08	I
7	7.20E-01	3.0E-06	1.31E+04	7.23E-10	2.45E+08	I
8	9.20E-01	4.2E-06	1.68E+04	7.92E-10	2.24E+08	I
9	9.60E-01	2.8E-06	1.75E+04	5.06E-10	3.50E+08	I
10	7.60E-01	4.4E-06	1.39E+04	1.00E-09	1.76E+08	I
1	2.20E-01	3.8E-06	4.01E+03	9.48E-10	1.87E+08	II
2	1.90E-01	3.5E-06	3.46E+03	1.01E-09	1.75E+08	II
3	2.20E-01	3.2E-06	4.01E+03	7.98E-10	2.22E+08	II
4	2.30E-01	3.2E-06	4.19E+03	7.63E-10	2.32E+08	II
5	1.60E-01	3.6E-06	2.92E+03	1.23E-09	1.44E+08	II
6	1.30E-01	3.6E-06	2.37E+03	1.52E-09	1.17E+08	II
7	1.50E-01	3.6E-06	2.73E+03	1.32E-09	1.35E+08	II
8	1.90E-01	2.6E-06	3.46E+03	7.51E-10	2.36E+08	II
9	2.10E-01	3.0E-06	3.83E+03	7.84E-10	2.26E+08	II
10	1.70E-01	3.2E-06	3.10E+03	1.03E-09	1.72E+08	II
1	2.60E-02	7.0E-07	4.74E+02	1.48E-09	1.20E+08	III
2	2.10E-02	7.2E-07	3.83E+02	1.88E-09	9.42E+07	III
3	2.70E-02	1.5E-06	4.92E+02	3.05E-09	5.81E+07	III
4	2.70E-02	6.8E-07	4.92E+02	1.38E-09	1.28E+08	III
5	1.90E-02	1.3E-06	3.46E+02	3.75E-09	4.72E+07	III
6	1.50E-02	1.2E-06	2.73E+02	4.39E-09	4.04E+07	III
7	1.70E-02	6.0E-07	3.10E+02	1.94E-09	9.15E+07	III
8	2.50E-02	9.0E-07	4.56E+02	1.98E-09	8.97E+07	III
9	2.50E-02	8.0E-07	4.56E+02	1.76E-09	1.01E+08	III
10	2.10E-02	7.0E-07	3.83E+02	1.83E-09	9.69E+07	III
1	2.60E-03	3.2E-07	5.99E+01	5.34E-09	3.32E+07	IV
2	2.60E-03	3.4E-07	5.99E+01	5.68E-09	3.12E+07	IV
3	3.00E-03	1.2E-06	6.91E+01	1.74E-08	1.02E+07	IV
4	3.20E-03	1.7E-07	7.37E+01	2.31E-09	7.68E+07	IV
5	2.20E-03	1.1E-06	5.07E+01	2.17E-08	8.16E+06	IV
6	1.80E-03	7.2E-07	4.15E+01	1.74E-08	1.02E+07	IV
7	2.00E-03	1.6E-07	4.61E+01	3.47E-09	5.10E+07	IV
8	2.40E-03	4.8E-07	5.53E+01	8.68E-09	2.04E+07	IV
9	2.40E-03	2.8E-07	5.53E+01	5.07E-09	3.50E+07	IV
10	2.20E-03	1.6E-07	5.07E+01	3.16E-09	5.61E+07	IV

**NOTES:** I) 7.6 m to 14.6 m, 500K, 1 Hz, 1Hz BW, Measured with a 0.1 Hz BW and normalized to 1 Hz.  
 II) 7.6 m to 14.6 m, 500K, 10 Hz, 1Hz BW  
 III) 7.6 m to 14.6 m, 500K, 100 Hz, 1Hz BW  
 IV) 7.6 m to 14.6 m, 500K, 1000 Hz, 1Hz BW  
 Supply Voltage: + 8 V DC at 25°C, 100,000 Ohms Source Resistor