

High Intensity Pulsed Laser Diodes 1550 HI-Series

Features

- High intensity output
- Low divergence
- Excellent temperature stability
- Hermetic and custom designed package
- High reliability

Applications

- Eye safe range finding
- Surveying equipment
- "Friend or Foe" identification
- Laser radar
- Security barrier

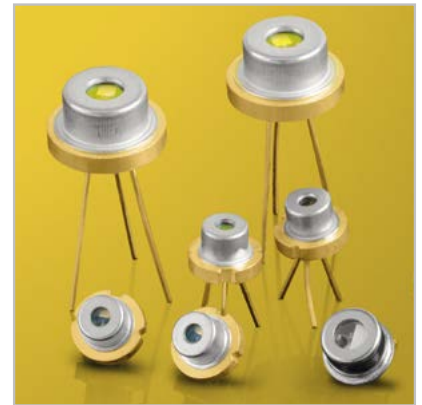

Optical Characteristics at $t_{RT} = 21^{\circ}\text{C}$, I_{FM}

	Min	Typ	Max	Units
Wavelength of peak radiant intensity λ	1540	1555	1580	nm
Spectral bandwidth $\Delta\lambda$ at 50% intensity points at i_{FM}		25		nm
Wavelength temperature coefficient		0.6		nm/ $^{\circ}\text{C}$
Beam spread (50% peak intensity)				
Parallel to junction plane \parallel		12		Degrees
Perpendicular to junction plane \perp		25		Degrees

Single Chips

Single chip characteristics at $t_{RT} = 21\text{ °C}$, $t_w = 150\text{ ns}$, $P_{rr} = 3.33\text{ kHz}$

Parameter	HI155G1S02X	HI155G1S04X	HI155G1S07X	HI155G1S14X**
P_O at I_{FM} (typ.)	8 W	16 W	20 W	30 W
Emitting area	50 μm	100 μm	180 μm	350 μm
Max peak forward current I_{FM}^*	45 A	60 A	65 A	80 A
I_{TH} typ	0.3 A	0.6 A	0.9 A	2 A
Forward voltage at I_{FM}	10 V	9 V	8 V	7.5 V

* I_{FM} is the maximum peak current under any drive condition and is applicable to devices operated for short and intermittent duration such as in hand held range finders.

For applications that demand continuous use at maximum duty factor, we recommended I_{FM} at 50% to ensure longevity. High temperature operation will reduce peak power and MTF so for optimal performance under high stress conditions it is important to provide an adequate heat sink.

** Only available on request.

Absolute Maximum Ratings

Maximum ratings	Limiting values
Peak reverse voltage	6 V
Pulse duration	150 ns
Duty factor	0.1%
Temperature	
- Storage	-55 °C to + 100 °C
- Operating	-45 °C to + 85 °C
Lead soldering	
- 5 seconds max at	200 °C

Note:

High Temperature operation will reduce peak power and MTF so for optimal performance it is important to provide an adequate heat sink.

Figure 1:
Peak Power vs. Current for 50 μm , 100 μm
(150 ns, 3 kHz, 21°C, F/0)

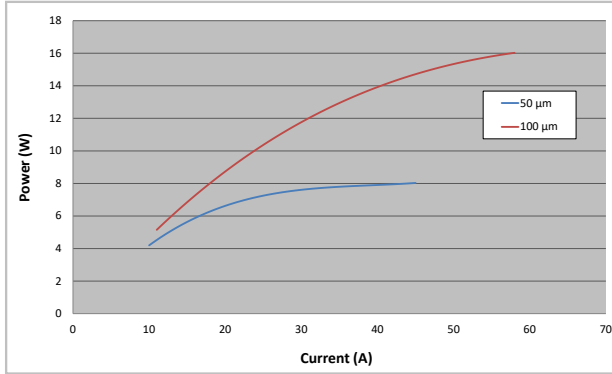

Figure 2:
Peak Power vs. Current for 180 μm , 350 μm
(150 ns, 3 kHz, 21°C, F/0)

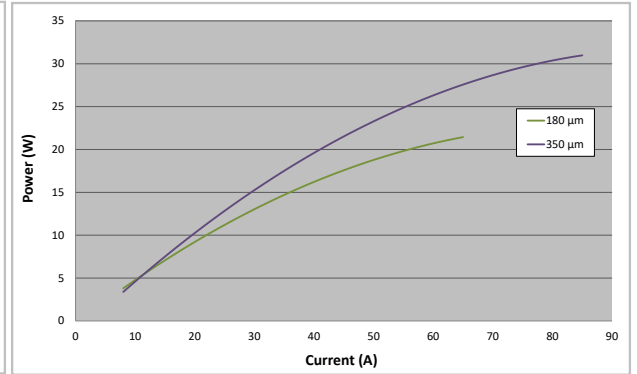

Figure 3:
Collection into Reducing Aperture Size

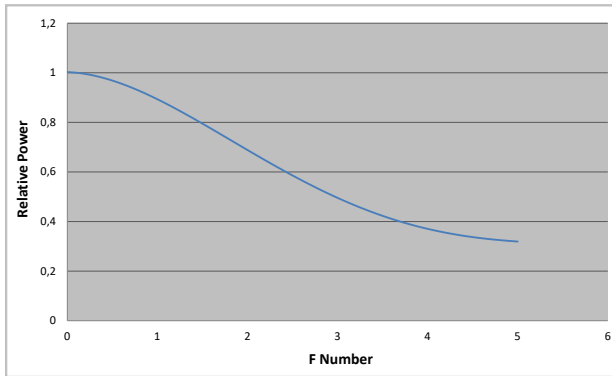

Figure 4:
Power Output vs. Temperature

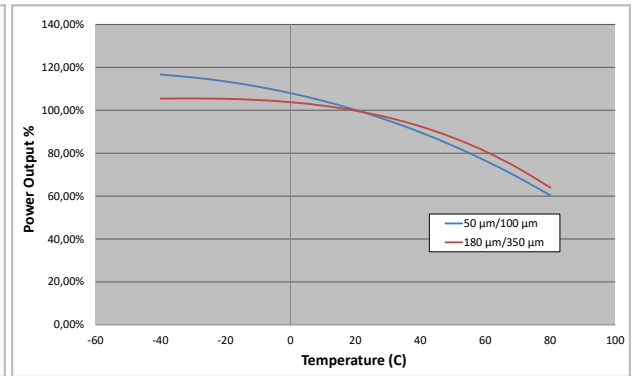

Figure 5:
Forward Voltage vs. Current

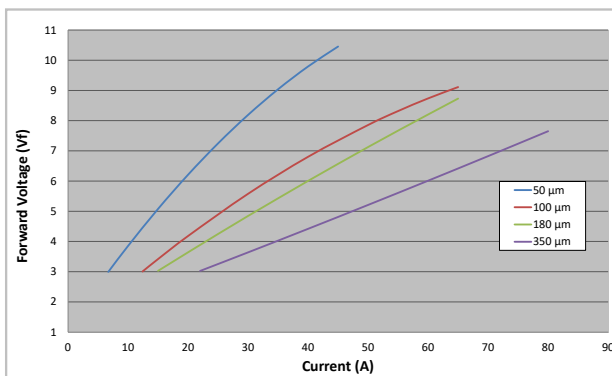

Figure 6:
Wavelength vs. Temperature

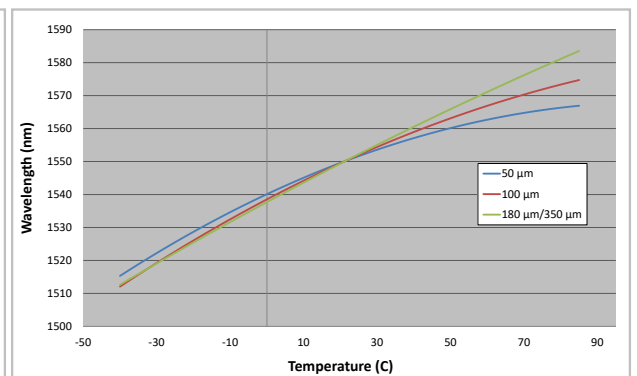

Figure 7:
Far field emission parallel and perpendicular to junction plane

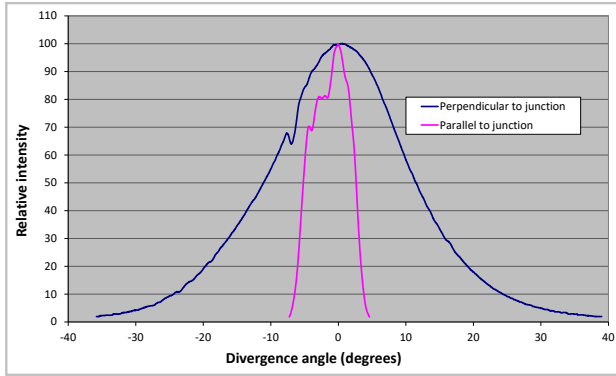
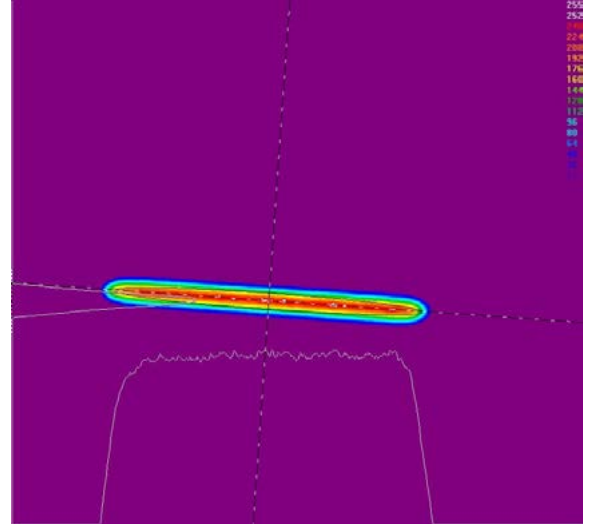
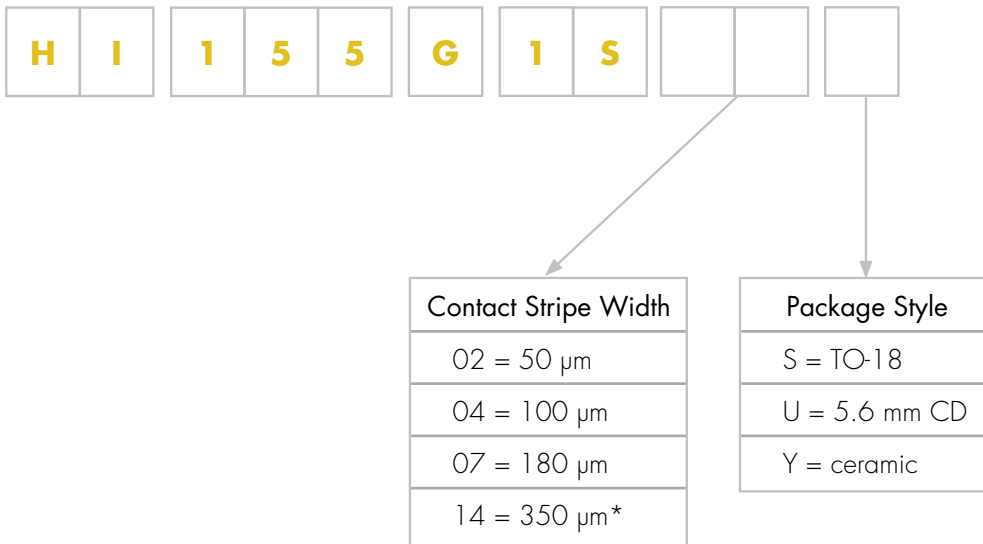

Figure 8:
Near field emission



Product Number Designations



* Only available on request.

Package Drawings

Package S TO-18

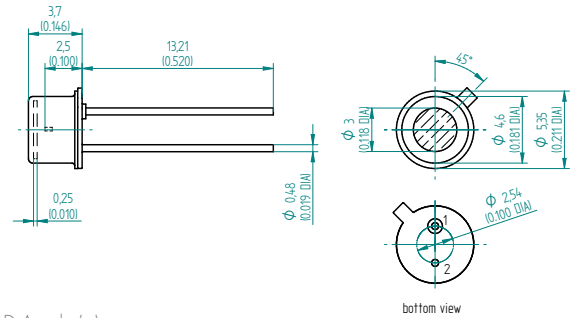

Package S: Pin Out: 1. LD Anode (+),
2. LD Cathode (-) Case,
Inductance 5.2 nH

Package U 5.6 mm CD

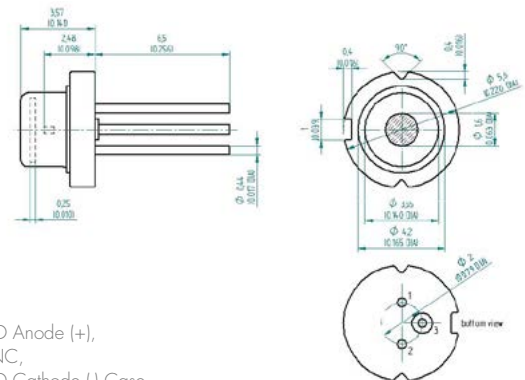

Package U: Pin Out: 1. LD Anode (+),
2. NC,
3. LD Cathode (-) Case,
Inductance 5.0 nH

Package Y ceramic carrier

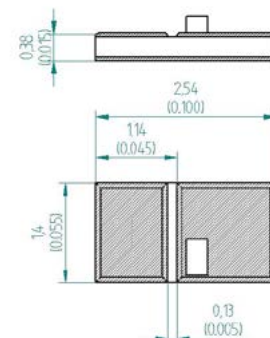
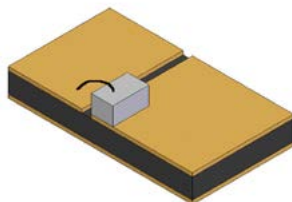

Package U: Pin Out: 1. LD Anode (+),
2. LD Cathode (-) Case,
Inductance 1.6 nH

Product Changes

LASER COMPONENTS reserves the right to make changes to the product(s) or information contained herein without notice. No liability is assumed as a result of their use or application.

Ordering Information

Products can be ordered directly from LASER COMPONENTS or its representatives. For a complete listing of representatives, visit our website at www.lasercomponents.com

Custom designed products are available on request.

Laser Safety

Personal Hazard:

Depending on the mode of operation, these devices emit highly concentrated non visible infrared light which can be hazardous to the human eye. Products which incorporate these devices have to follow the safety precautions given in IEC 60825-1 "Safety of laser products".

Handling Precautions:

Products are subject to the risks normally associated with sensitive electronic devices including static discharge, transients, and overload.

