

Alternate Source/ Second Source Photodiodes

VTD31AAH (CLD31AA INDUSTRY EQUIVALENT)

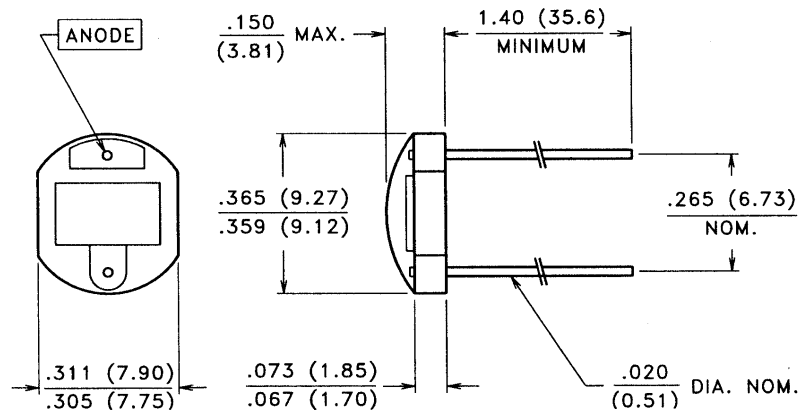

PACKAGE DIMENSIONS inch (mm)



CASE 13 CERAMIC
CHIP ACTIVE AREA: .026 in² (16.73 mm²)

PRODUCT DESCRIPTION

Planar silicon photodiode mounted on a two lead ceramic substrate and coated with a thick layer of clear epoxy. These diodes exhibit low dark current under reverse bias and fast speed of response.

ABSOLUTE MAXIMUM RATINGS

Storage Temperature: -20°C to 75°C
Operating Temperature: -20°C to 75°C

RoHS Compliant



ELECTRO-OPTICAL CHARACTERISTICS @ 25°C

SYMBOL	CHARACTERISTIC	TEST CONDITIONS	VTD31AAH			UNITS
			Min.	Typ.	Max.	
I _{SC}	Short Circuit Current	H = 5 mW/cm ² , 2850 K	150		225	μA
TC I _{SC}	I _{SC} Temperature Coefficient	2850 K		.20		%/°C
V _{OC}	Open Circuit Voltage	H = 5 mW/cm ² , 2850 K		350		mV
TC V _{OC}	V _{OC} Temperature Coefficient	2850 K		-2.0		mV/°C
I _D	Dark Current	H = 0, V _R = 15 V			50	nA
C _J	Junction Capacitance	H = 0, V = 0 V			500	pF
S _R	Sensitivity	@ Peak		.55		A/W
λ _{range}	Spectral Application Range		400		1150	nm
λ _p	Spectral Response - Peak			860		nm
V _{BR}	Breakdown Voltage		5			V
θ _{1/2}	Angular Resp.-50% Resp. Pt.			±60		Degrees