

# High Power 14-Pin DFB Butterfly Fiber Module



## Part Number: 14BF-451

High Power 14-Pin DFB Butterfly Fiber Coupled Module  
Single-Mode DFB  
Wavelength at 1550nm

## Features

- High Output Power
- High Efficiency
- Polarization Maintenance Fiber
- Isolator Included

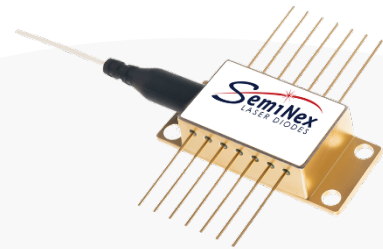

## Application

- LiDAR
- Free Space Communications
- Optical Fiber Communications
- Network Test Equipment



SemiNex delivers the highest available power at infrared wavelengths between 12xx and 19xx nm. When necessary, we will further optimize the design of our InP & GaSb laser chips to meet our customers' specific optical and electrical performance needs. Diodes, bars and packages are tested to meet customer and market performance demands. Typical results and packaging options are shown. Contact SemiNex for additional details or to discuss your specific requirements.

# High Power 14-Pin DFB Butterfly Fiber Module



## Specification

14BF-451

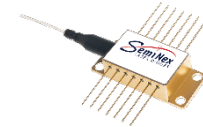

Optical	Symbol	Typ.	Units
Center Wavelength	$\lambda_c$	1550	nm
Output Power	$P_{out}$	40	mW
Linewidth	$\Delta f$	140	kHz
Side Mode Suppression Ratio	SMSR	>50	dB
Relative Intensity Noise	RIN	-150	dBc/Hz
Electrical	Symbol		Units
Power Conversion Eff.	$\eta$	9	%
Operating Voltage	$V_{op}$	1.75	V
Operating Current	$I_{op}$	500	mA
Threshold Current	$I_{TH}$	30	mA
Fiber Package	Symbol		Units
Fiber Core		8	$\mu m$
Connector Type		FC / APC	
Fiber Length		1	m
Pinout Type		Type 1	
Thermistor			
Thermistor Constant	$\beta$	3930	$\beta$
Thermistor Resistance	R	10	K ohm
Voltage (TEC) – Typ, Max	$V_{TEC}$	2, 8.2	V
Current (TEC) – Typ, Max	$I_{TEC}$	0.3, 2.6	A
		Range	
Temperature Coefficient		0.11	nm/°C
Operating Temp.**		-20 to 75	°C
Storage Temp.		-40 to 85	°C

Specified values are rated at a constant heat sink temperature of 20°C.

\*\*High temperature operation will reduce performance and MTTF.

Unless otherwise indicated all values are nominal.

# High Power 14-Pin DFB Butterfly Fiber Module



## SemiNex DFB Butterfly 14BF-451

Graphs & Data  
Typical DFB Butterfly L-I-V Characteristics

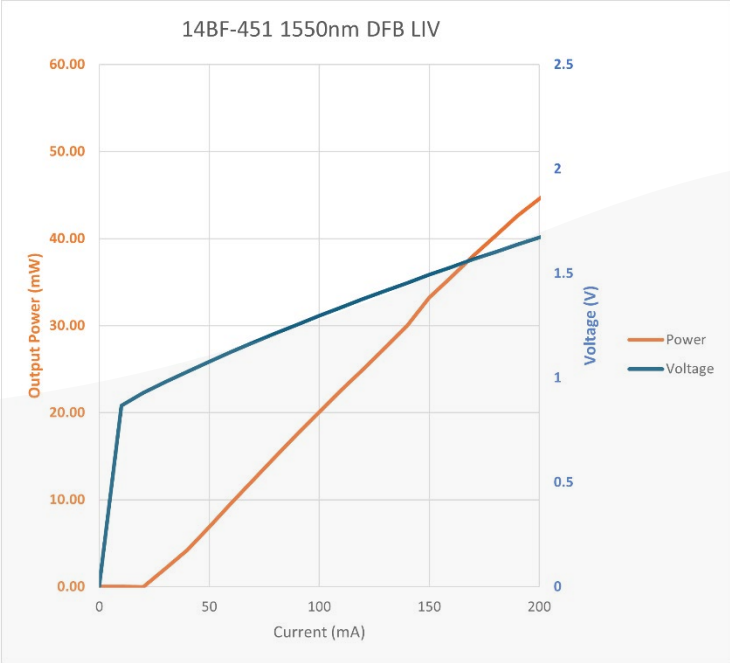
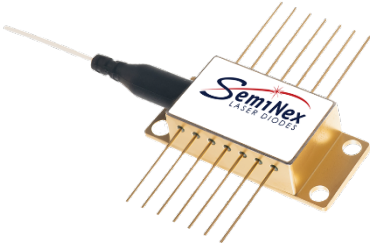

## Typical DFB Butterfly Output Spectrum

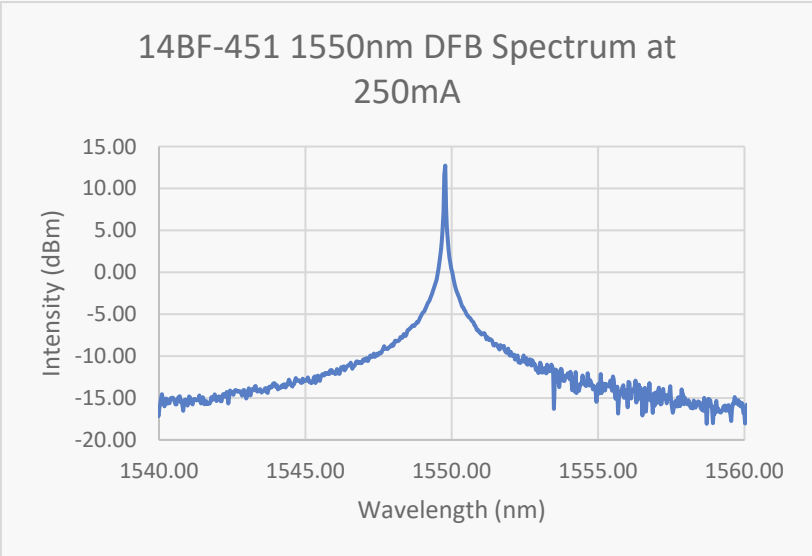

# High Power 14-Pin DFB Butterfly Fiber Module



## Mechanical Drawing

1	Thermoelectric Cooler (+)
2	Thermistor
3	MPD Anode (+)
4	MPD Cathode (-)
5	Thermistor
6	NC
7	NC
8	NC
9	NC
10	LD Anode (+)
11	LD Cathode (-)
12	NC
13	NC
14	Thermoelectric Cooler (-)

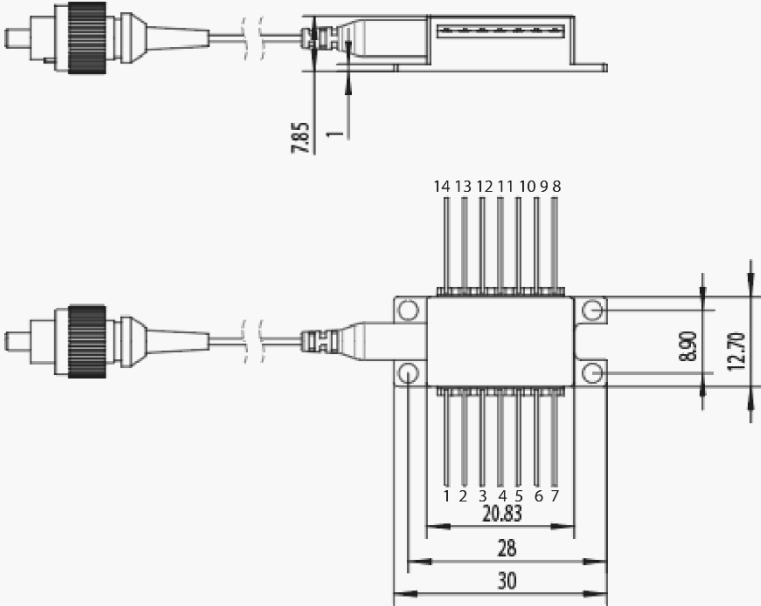
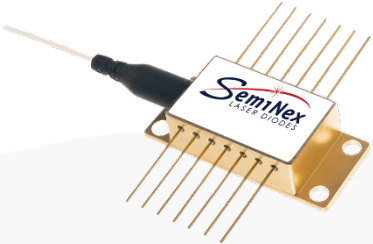

All statements, technical information and recommendations related to the product herein are based upon information believed to be reliable or accurate. The accuracy or completeness herein is not guaranteed, and no responsibility is assumed for any inaccuracies. The user assumes all risks and liability whatsoever in connection with the use of a product or its application. SemiNex Corporation reserves the right to change at any time without notice the design, specification, deduction, fit or form of its described herein, including withdrawal at any time of a product offered for sale herein. Users are encouraged to visit [www.seminex.com](http://www.seminex.com) for the latest data. SemiNex Corporation makes no representations that the products herein are free from any intellectual property claims of others. Please contact SemiNex for more information. 2024 SemiNex Corporation

SemiNex Corporation • 153 Andover Street, Suite 201, Danvers, MA 01923 • 978-326-7700 • [sales@seminex.com](mailto:sales@seminex.com)

