

V00140

Die; 2222; 895; S; 1M; S5,S6,S7; 0.2mW; 0.16X0.20

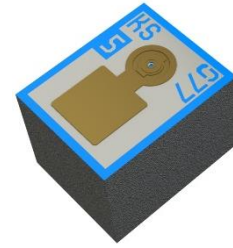

Applications

- Atomic Clock
- Magnetometer

Features:

- Package Description: Bare Die
- Chip Technology: GaAs VCSEL
- Laser Wavelength: 894.6 nm
- Radiation Profile: Single Mode
- ESD: 250 V acc. to ANSI/ESDA/JEDEC JS-001 (HBM, Class 1A)

Ordering Information

Description	Operating Mode:	Ordering Code
Group 1 - Die; 2222; 895; S; 1M; S5,S6,S7; 0.2mW; 0.16X0.20	$T_a = 60 \pm 10^\circ\text{C}$; $I_F = 1.4 \text{ mA}$; DC = 100%, 894.6nm	V00140 Group: 1
Group 2 - Die; 2222; 895; S; 1M; S5,S6,S7; 0.2mW; 0.16X0.20	$T_a = 70 \pm 10^\circ\text{C}$; $I_F = 1.4 \text{ mA}$; DC = 100%, 894.6nm	V00140 Group: 2
Group 3 - Die; 2222; 895; S; 1M; S5,S6,S7; 0.2mW; 0.16X0.20	$T_a = 80 \pm 10^\circ\text{C}$; $I_F = 1.4 \text{ mA}$; DC = 100%, 894.6nm	V00140 Group: 3
Group 4 - Die; 2222; 895; S; 1M; S5,S6,S7; 0.2mW; 0.16X0.20	$T_a = 90 \pm 10^\circ\text{C}$; $I_F = 1.4 \text{ mA}$; DC = 100%, 894.6nm	V00140 Group: 4
Group 5 - Die; 2222; 895; S; 1M; S5,S6,S7; 0.2mW; 0.16X0.20	$T_a = 100 \pm 10^\circ\text{C}$; $I_F = 1.4 \text{ mA}$; DC = 100%, 894.6nm	V00140 Group: 5



COMPLIES WITH IEC 60825-1, 3rd EDITION MAY 2014.
COMPLIES WITH 21 CFR 1040.10 AND 1040-10.11 EXCEPT FOR DEVIATIONS PURSUANT TO LASER
NOTICE NO.50 DATED 27 MAY 2001.

Maximum Ratings

$T_a = 80^\circ\text{C}$

Parameter	Symbol		Values
Operation/Solder temperature DC = 100%	T_S	min.	-20°C
		max.	110°C
Storage temperature	T_{stg}	min.	-40°C
		max.	125°C
Forward current to remain single mode Direct current operation; DC = 100%; $T_S = 75^\circ\text{C}$	I_f	max.	1.5 mA
Forward current Direct current operation; DC = 100%; $T_S = 75^\circ\text{C}$		max.	3 mA
Reverse Voltage	Not designed for reverse operation		
ESD withstand voltage acc. to ANSI/ESDA/JEDEC JS-001 (HBM, Class 1A)	V_{ESD}	max.	250 V

Note: Stresses beyond those listed under Absolute Maximum Ratings may cause permanent damage to the device.

Characteristics

$T_a = 80^\circ\text{C}$, $I_F = 1.4 \text{ mA}$; DC = 100% - Group 3

Parameter	Symbol		Values
Forward voltage	V_F	typ.	1.78 V
Output power	Φ	typ.	0.3 mW
Threshold current	I_{th}	typ.	0.61 mA
Slope efficiency	SE	typ.	0.37 W / A
Single-mode Suppression Ratio	SMSR	min.	20 dB
Polarization Extinction Ratio ⁵⁾	PER	min.	15 dB
Peak wavelength (vacuum)	λ_{peak-v}	min.	894.1 nm
		typ.	894.6 nm
		max.	895.1 nm
Spectral linewidth	$\Delta\lambda_{linewidth}$	max.	100 MHz
FM Modulation Bandwidth	Fm	min.	4.6 GHz
Temperature coefficient of wavelength	TC_λ	typ.	0.06 nm / K
Field of view at FWHM (50% of Φ_{max})	ϕ_x	typ.	12°
	ϕ_y	typ.	12°
Field of view at $1/e^2$	ϕ_x	typ.	20°
	ϕ_y	typ.	20°

Note: Wavelength, Output power and Voltage changes based on operating temp.

Relative Spectral Emission ¹⁾

$$\Phi_{\text{rel}} = f(\lambda); I_F = 1.4 \text{ mA}$$

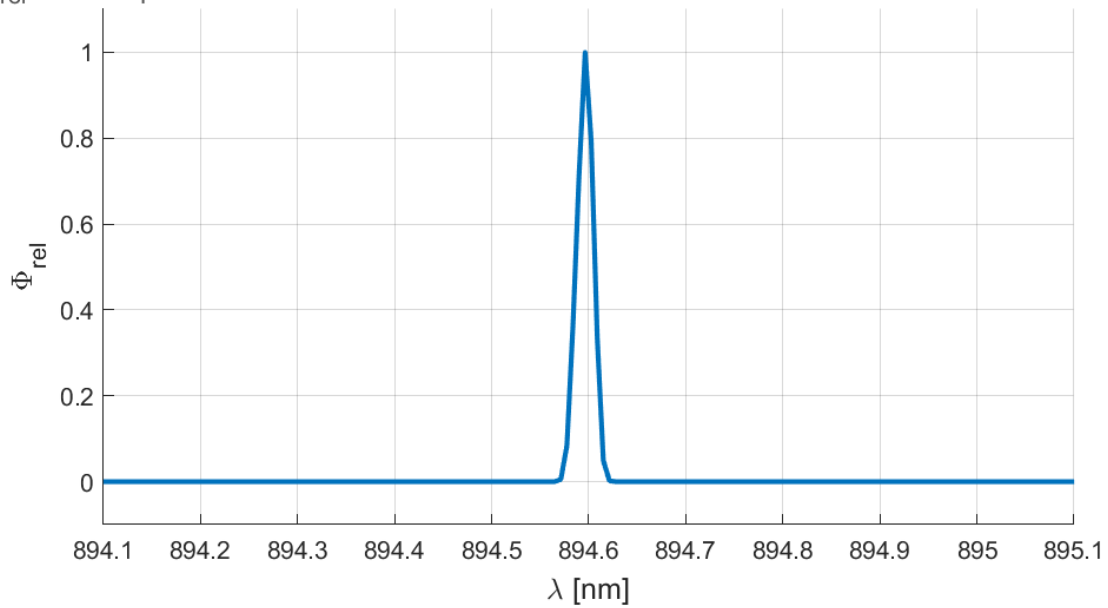
**Radiation Characteristics ¹⁾**

$$\Phi_{\text{rel}} = f(\phi); T_S = 60 \text{ }^\circ\text{C}$$

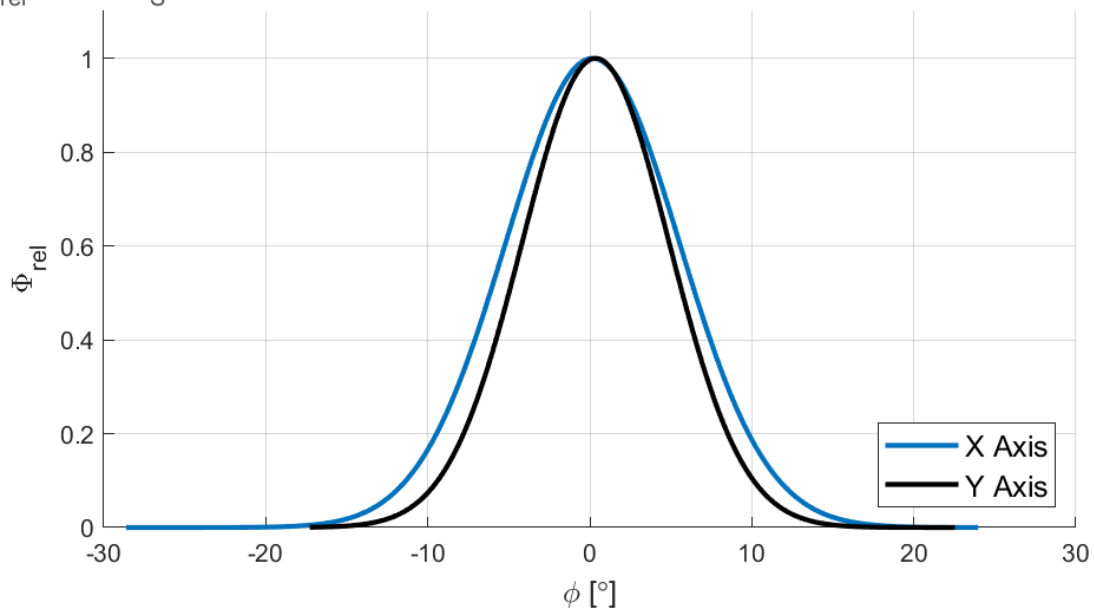

Forward Voltage ^{1) 2)}

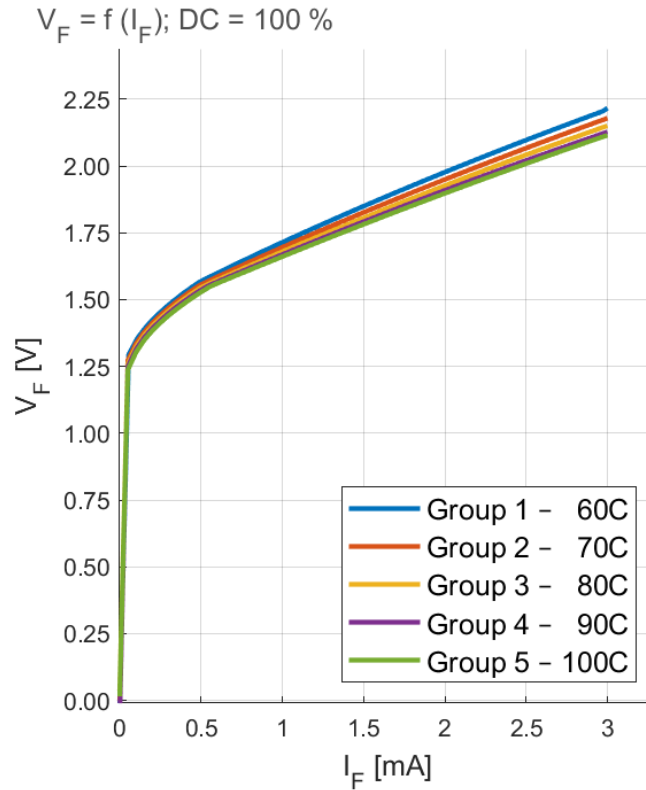

Optical Output Power ^{1) 2)}

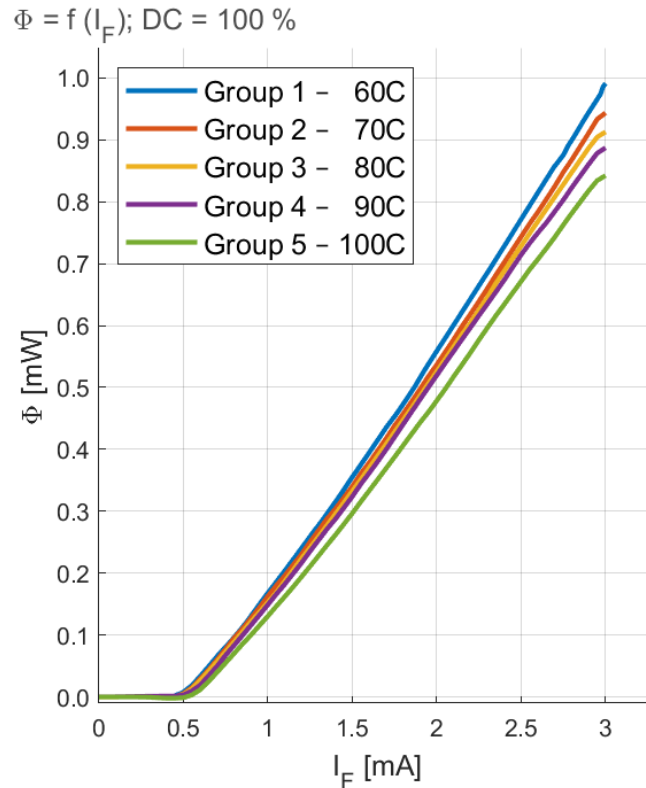

Dimension Drawings ³⁾

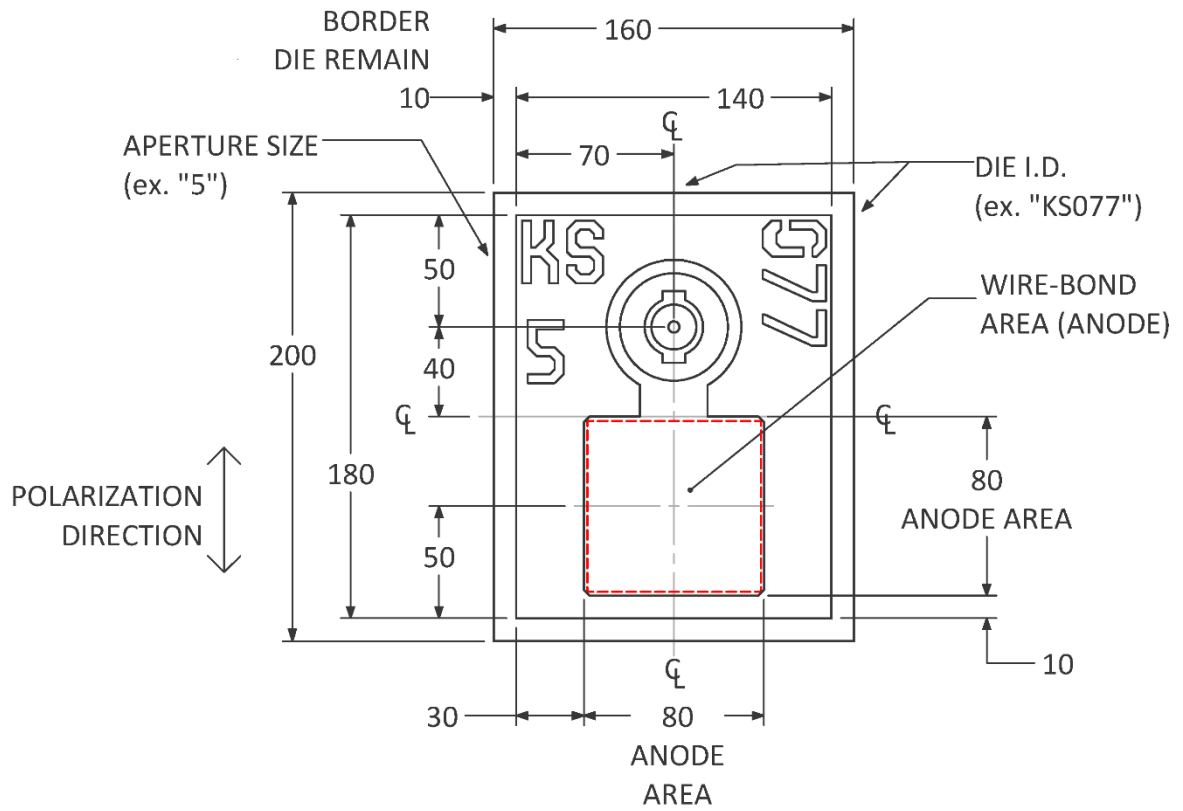

DASHED LINES (WIRE-BOND AREA) ARE NOT VISIBLE ON ACTUAL DIE

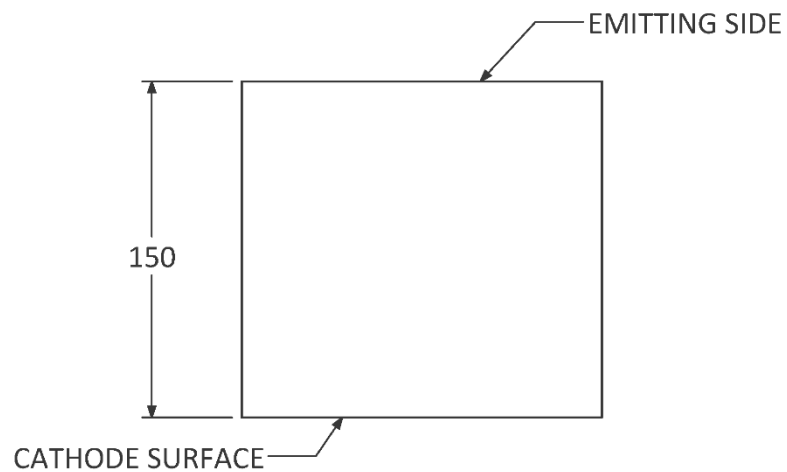

Product Label

VIXAR Vertical Cavity Surface Emitting Laser (VCSEL) Product

Model: Group:

Manufacturer: VIXAR INC.
2355 POLARIS AVE N. SUITE 100
Plymouth, MN 55447, USA

Manufactured: Bare Die by VIXAR,
Fabricated or Packaged by:
Vixar, Inc.
2355 POLARIS AVE N. SUITE 100
Plymouth, MN 55447, USA

Wafer #:
Mft Lot #:
Date Code:
Quantity:

Complies with FDA/CDRH 21 CFR 1040.10 and 1040.11 except
For deviations pursuant to Laser Notice No. 50, dated June 24, 2007.

CDRH Accession No.: 1210159-000 Product Code: 95R--DW

Packaging

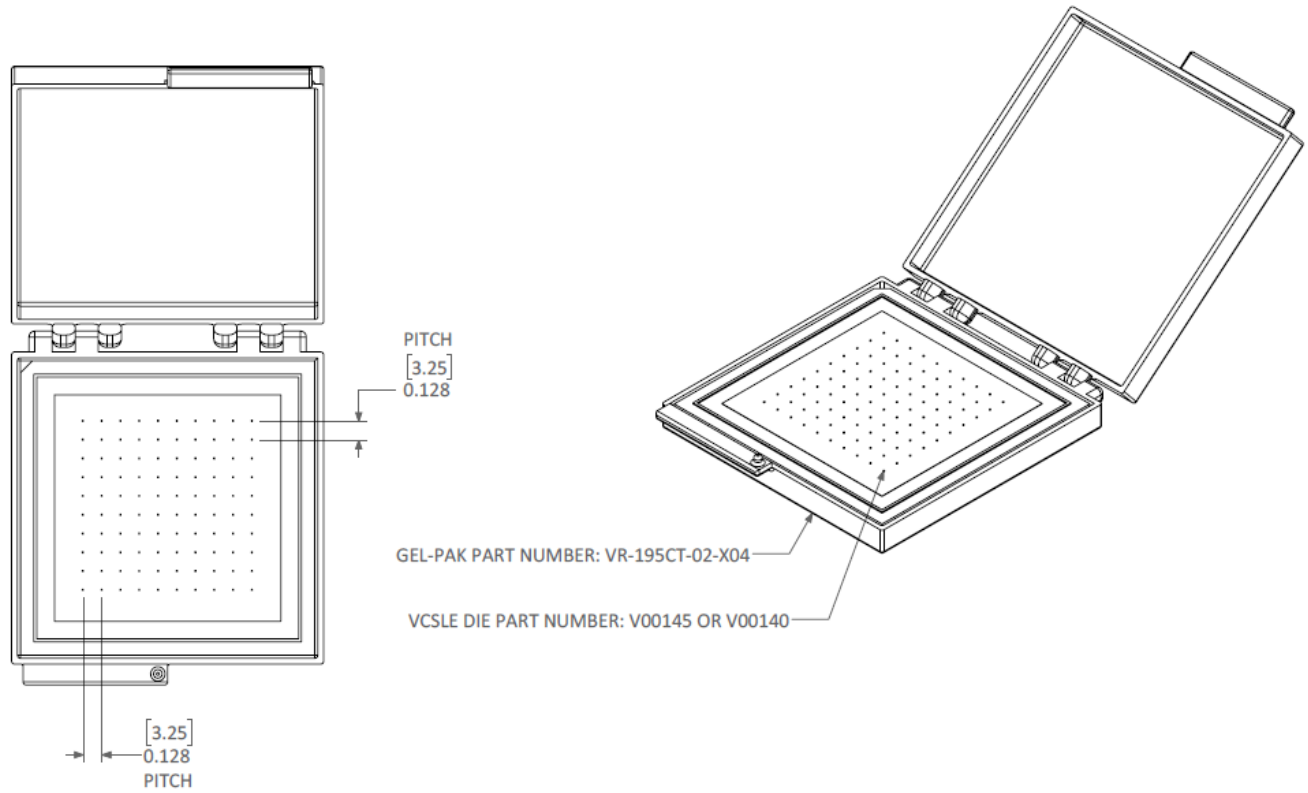

Pieces per Gel-Pak

100

Note: For sampling quantities please contact sales@vixarinc.com

Notes

Depending on the mode of operation, these devices emit highly concentrated visible and non-visible light which can be hazardous to the human eye. Products which incorporate these devices must follow the safety precautions given in IEC 60825-1.

Subcomponents of this device contain, in addition to other substances, metal filled materials including silver. Metal filled materials can be affected by environments that contain traces of aggressive substances. Therefore, we recommend that customers minimize device exposure to aggressive substances during storage, production, and use. Devices that showed visible discoloration when tested using the described tests above did show no performance deviations within failure limits during the stated test duration. Respective failure limits are described in the IEC60810.

For further application related information please visit <http://vixarinc.com/vcSEL-technology/application-notes>

Glossary

- 1) **Typical Values:** Due to the special conditions of the manufacturing processes of semiconductor devices, the typical data or calculated correlations of technical parameters can only reflect statistical figures. These do not necessarily correspond to the actual parameters of each single product, which could differ from the typical data and calculated correlations or the typical characteristic line. If requested, e.g. because of technical improvements, these typ. data will be changed without any further notice.
- 2) **Testing temperature:** $T_A = 80^{\circ}\text{C} \pm 2^{\circ}\text{C}$
- 3) **Tolerance of Measure:** Unless otherwise noted in drawing, tolerances are specified with ± 0.1 and dimensions are specified in mm.
- 4) **Wavelength:** The wavelength is measured at continuous wave, with resolution of ± 0.1 nm.
- 5) **Polarization:** The Polarization Extinction Ratio can be degraded under conditions of die stress induced by mounting or packaging.

Revision History

Version	Date	Change
0.0	December 10 – 2020	Initiation of preliminary datasheet
1.0	December 11 – 2020	Release of datasheet
1.1	February 25 – 2021	Update dimension drawing



COMPLIES WITH IEC 60825-1, 3rd EDITION MAY 2014.
COMPLIES WITH 21 CFR 1040.10 AND 1040-10.11 EXCEPT FOR DEVIATIONS PURSUANT TO LASER
NOTICE NO.50 DATED 27 MAY 2001.