

For a conventional SiPM, the quenching resistors are usually fabricated on the surface, and used to connect all APD cells to trace metal lines. In contrast, ZJGD SiPM employs intrinsic epitaxial layer as the quenching resistors (EQR), and uses a continuous silicon cap layer as an anode to connect all the APD cells. As a result, the device has more compact structure and simpler fabrication technology, allows larger micro cell density (larger dynamic range) while retaining high photon detection efficiency (PDE).

Features

- ◆ Small Cell and Pitch
- ◆ High Cell Density and Fill Factor
- ◆ Large Dynamic Range and High PDE
- ◆ Fast Rise Time and Narrow Pulse Width
- ◆ Short Recovery Time and High Time Resolution
- ◆ Small Terminal Capacitance and Cost Effective

Applications

- ◆ High Energy Physics
- ◆ Fluorescence Measurement
- ◆ Nuclear Medical Imaging (PET, SPECT)
- ◆ Radiation Detection and Imaging
- ◆ Optical Spectroscope
- ◆ Other Low Level Light Detection

Specifications

Type	EQR15 11-1010D-S	EQR15 11-3030D-S	EQR15 11-6060D-S	EQR15 22-1313D-S
Effective Pitch	15 μm			
Element Number	1 \times 1			2 \times 2
Active Area	1.0 \times 1.0 mm ²	3.0 \times 3.0 mm ²	6.14 \times 6.14 mm ²	1.3 \times 1.3 mm ²
Micro-cell Number	4444 /mm ²			
Typical Breakdown Voltage (V _B)	30 V			
Temperature Coefficient for V _B	28 mV/°C			
Recommended Operation Voltage	V _B + 8 V			
Peak PDE @ 420nm	45 %			
Gain	4.0 \times 10 ⁵			
Dark Count Rate (DCR)	250 kHz / mm ²			
Terminal Capacitance	5.6 pF / mm ²			

Above parameters are measured at their recommended operation voltage and 20 °C.

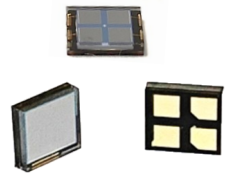

Characteristics

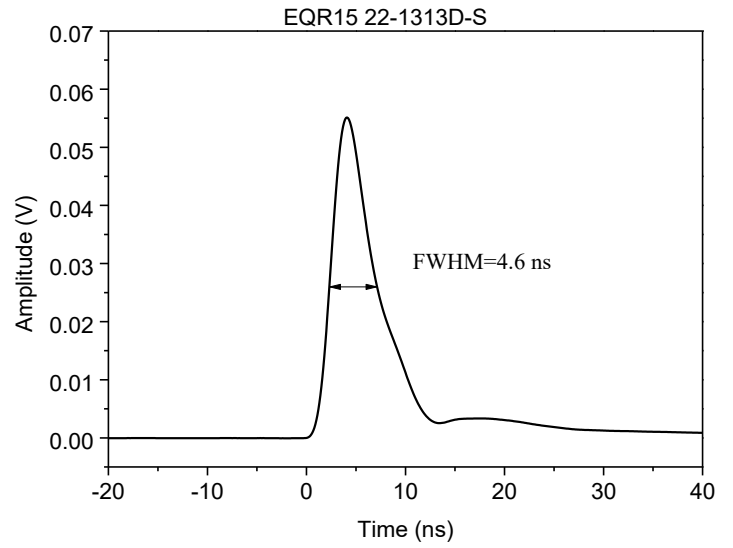
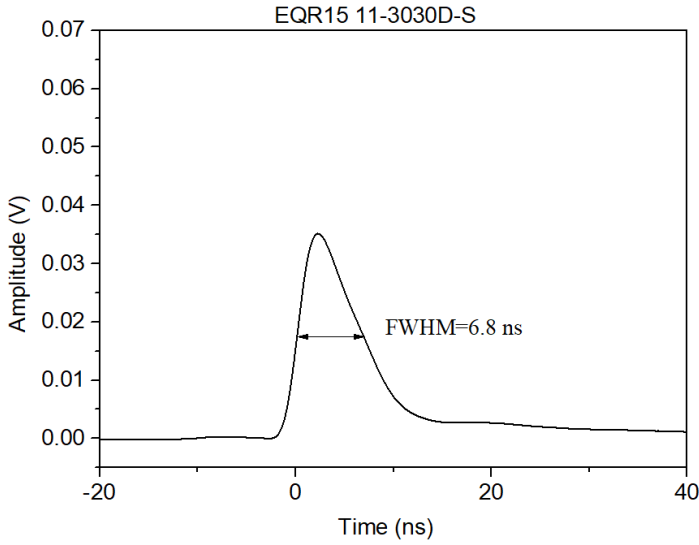

The single photoelectron pulse (amplified by a 40dB fast amplifier).

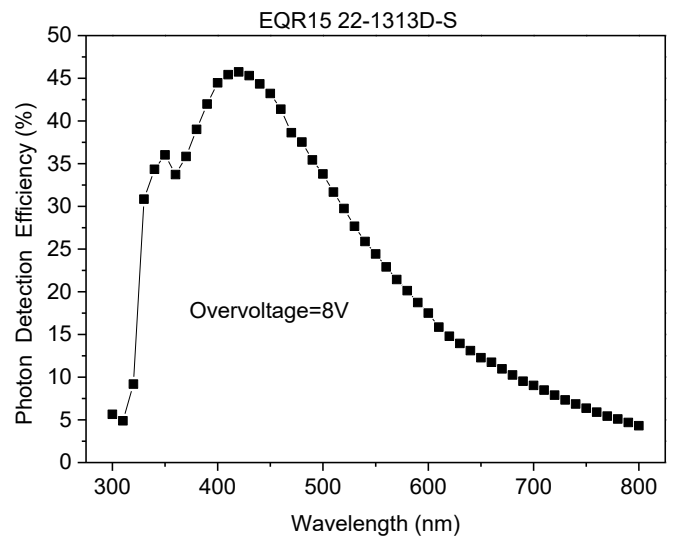
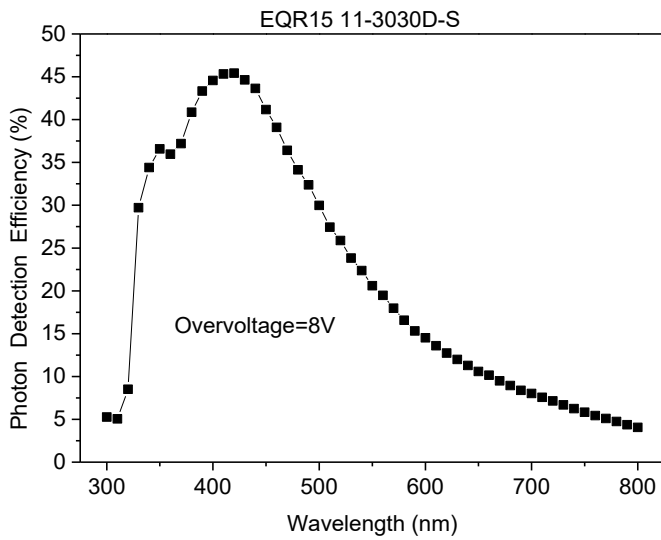

The PDE versus overvoltage and wavelength, deducted crosstalk and afterpulse and measured at 20 °C .

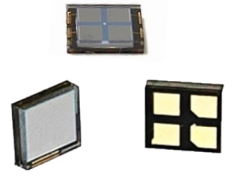

Dimensional outlines (unit: mm)

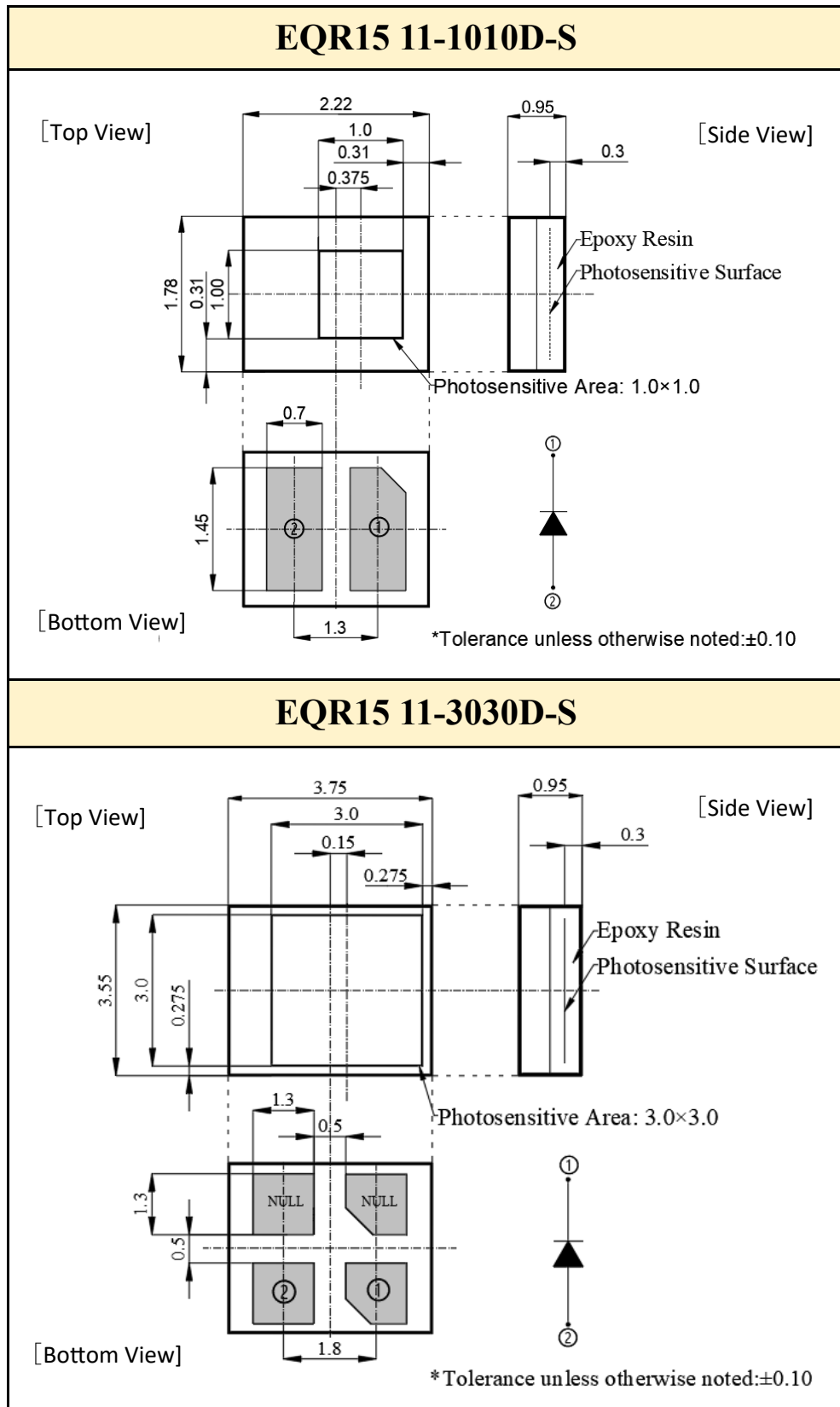



Dimensional outlines (unit: mm)

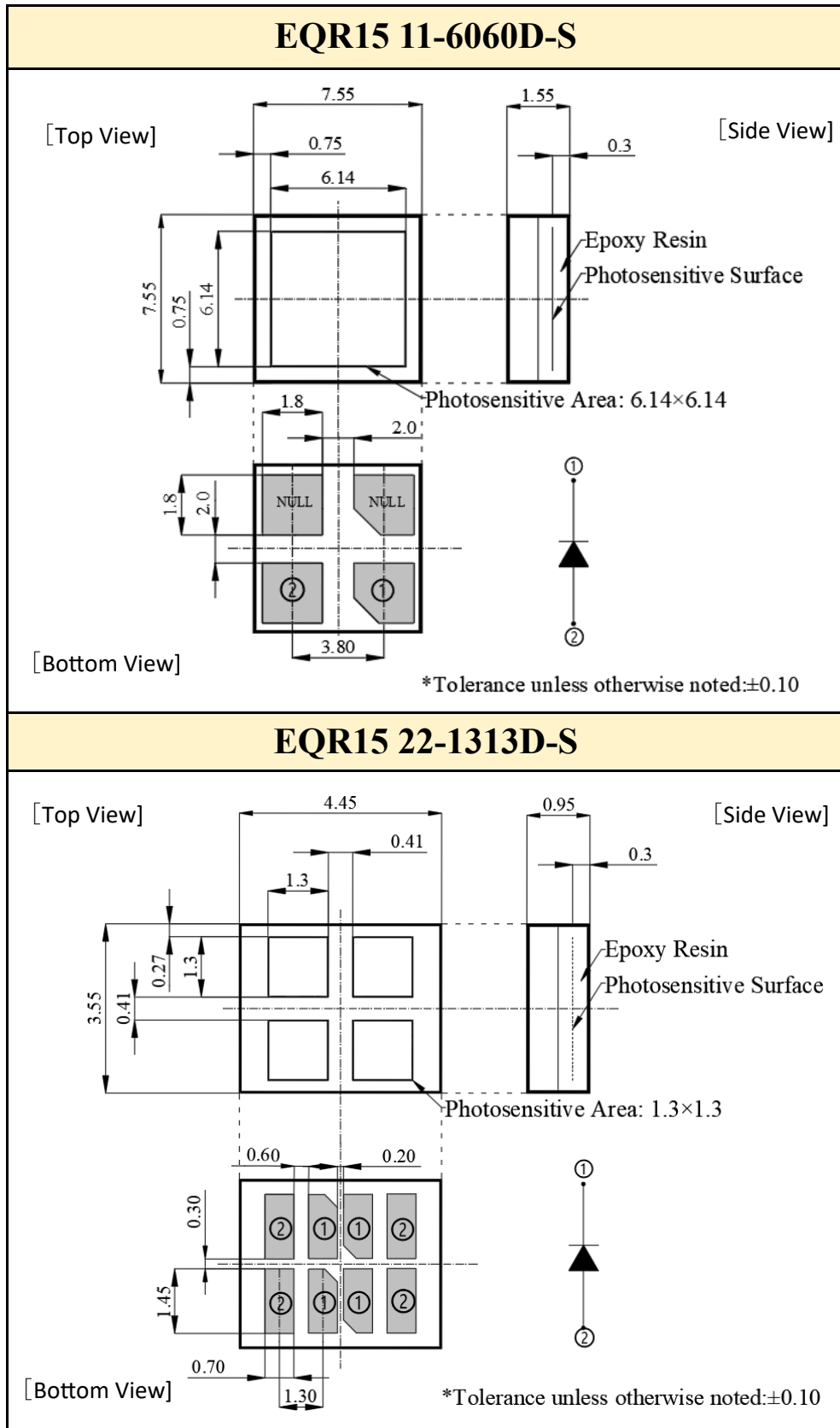

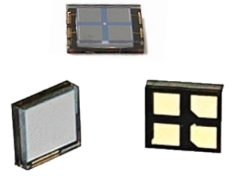

Recommended Solder Reflow Conditions

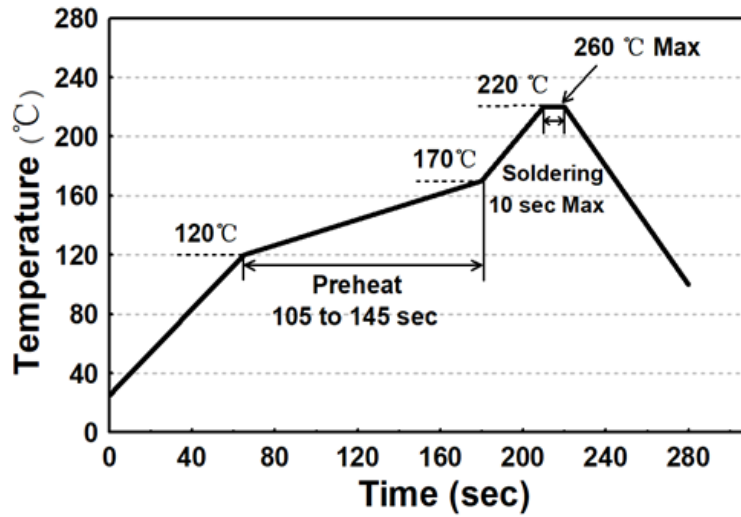

Basic Connection Diagrams

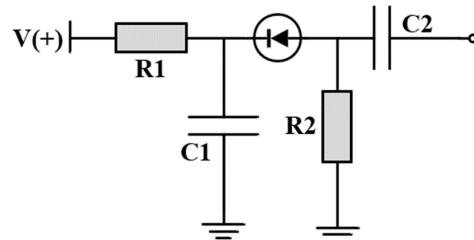

R1 = 10 kΩ
R2 = 1 kΩ
C1 = 100 nF
C2 = 10 nF

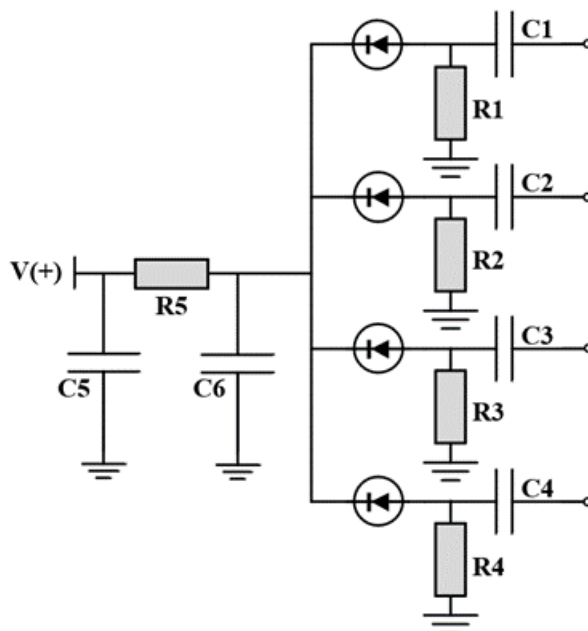

R1-4 = 1 kΩ
R5 = 50 Ω
C1-4 = 10 nF
C5 = 200 pF
C6 = 220 nF