

## High Power Pulsed Laser Diodes 850-Series

### Features

- Proven AlGaAs high reliability structure
- 0.9 W/A efficiency
- Excellent temperature stability
- Hermetic and custom designed package

### Applications

- Range finding
- Surveying equipment
- Weapons simulation
- Laser radar
- Security barrier
- Optical trigger



### Optical Characteristics at $t_{RT} = 21^{\circ}\text{C}$ , $I_{FM}$

	Min	Typ	Max	Units
Wavelength of peak radiant intensity $\lambda_m$	835	850	860	nm
Spectral bandwidth $\Delta\lambda$ at 50% intensity points		5.5		nm
Wavelength temperature coefficient		0.21		nm/ $^{\circ}\text{C}$
Beam spread (50% peak intensity)				
Parallel to junction plane $\parallel$		10.5		Degrees
Perpendicular to junction plane $\perp$		20		Degrees

## Single Chip

Single chip characteristics at  $t_{RT} = 21^\circ\text{C}$ ,  $t_w = 150\text{ ns}$ ,  $P_{rr} = 6.66\text{ kHz}$

Parameter	850D1S09-X
$P_O$ at $I_{FM}$ (typ.)	13 W
Emitting area	225 x 1 $\mu\text{m}$
Max peak forward current $I_{FM}$	18 A
$I_{TH}$ typ	900 mA
Forward voltage at $I_{FM}$	3 V

## Absolute Maximum Ratings

Maximum ratings	Limiting values
Peak reverse voltage	6 V
Pulse duration	150 ns
Duty factor	0.1%
Temperature	
- Storage	-55°C to + 100°C
- Operating	-45°C to + 85°C
Lead soldering	
- 5 seconds max at	200°C

Figure 1:  
Peak power vs Current

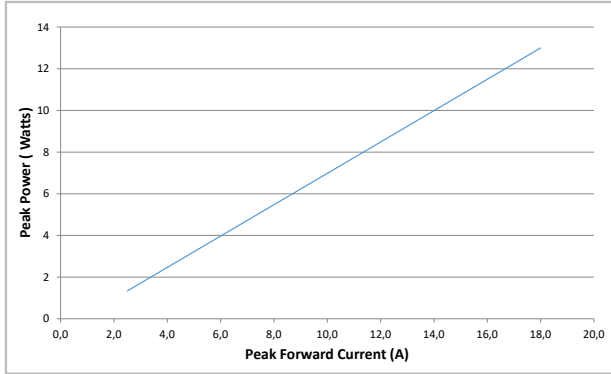

Figure 2:  
Static Forward voltage against current

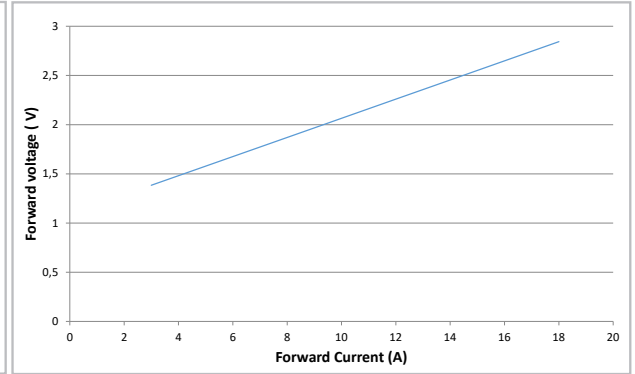

Figure 3:  
Peak power vs Temperature

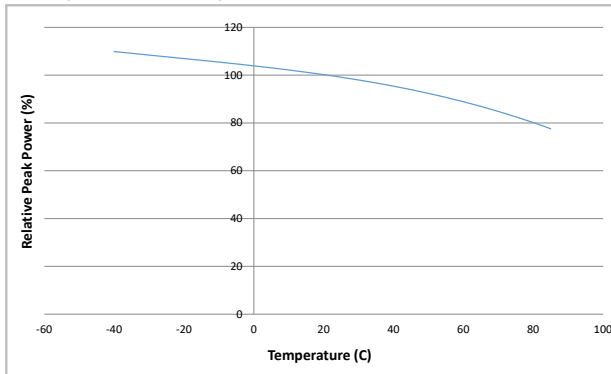

Figure 4:  
Wavelength

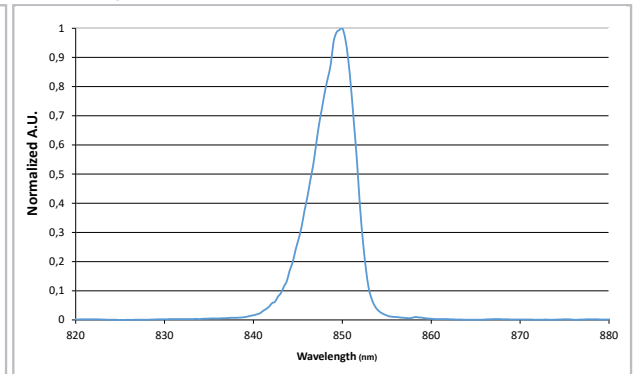
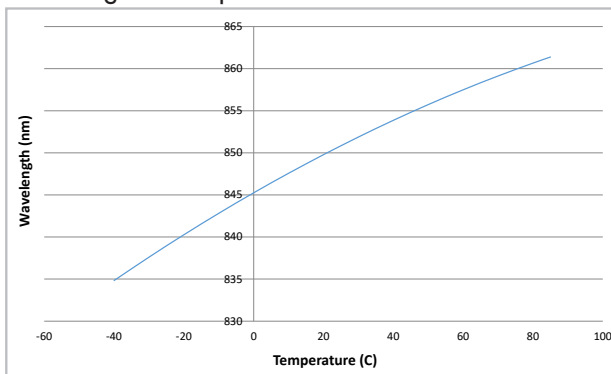
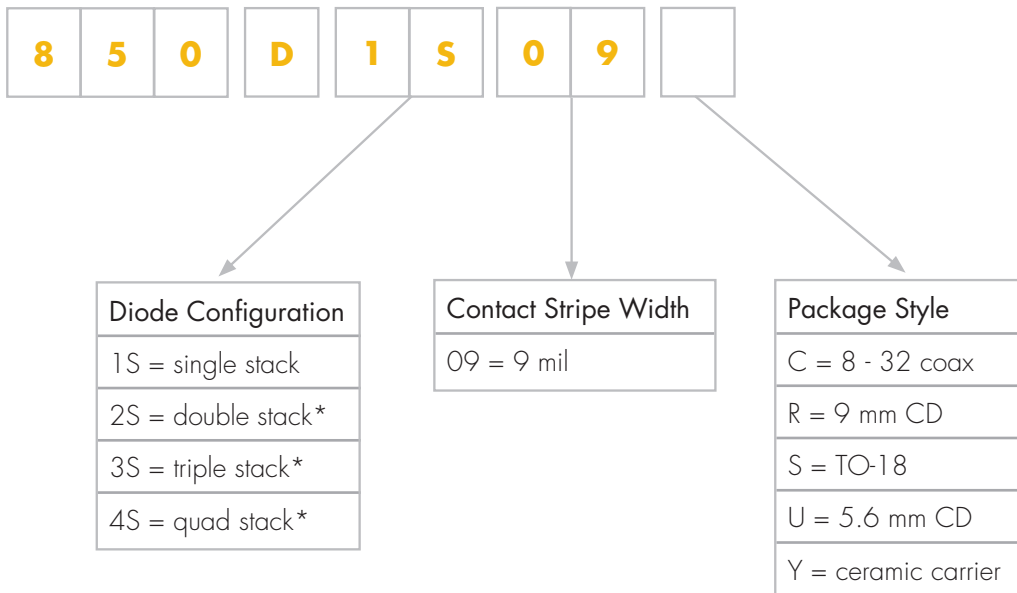

Figure 5:  
Wavelength vs Temperature



Product Number Designations



\* only available on request

Package Drawings

Package C 8 - 32 coax

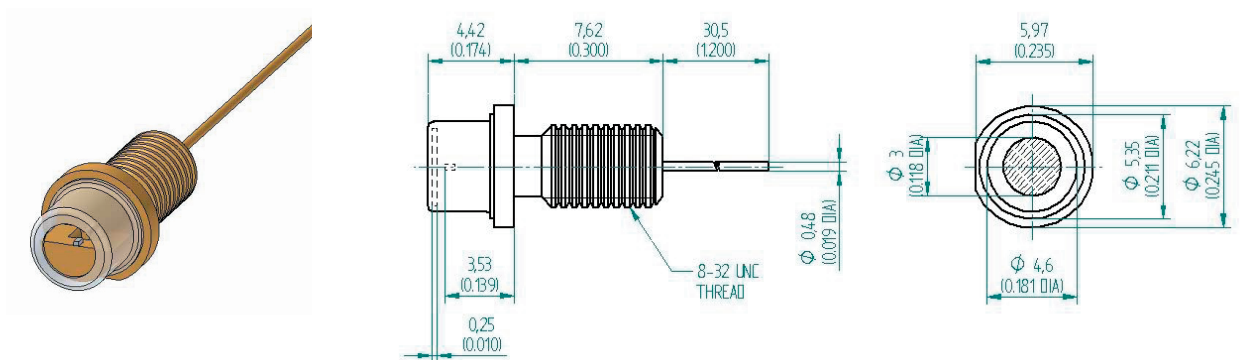

Package C: Pin Out: Case (-), Pin (+), Inductance 12 nH

10/19 / V05 / IF / lcp/d/850dseries

Package R 9 mm CD

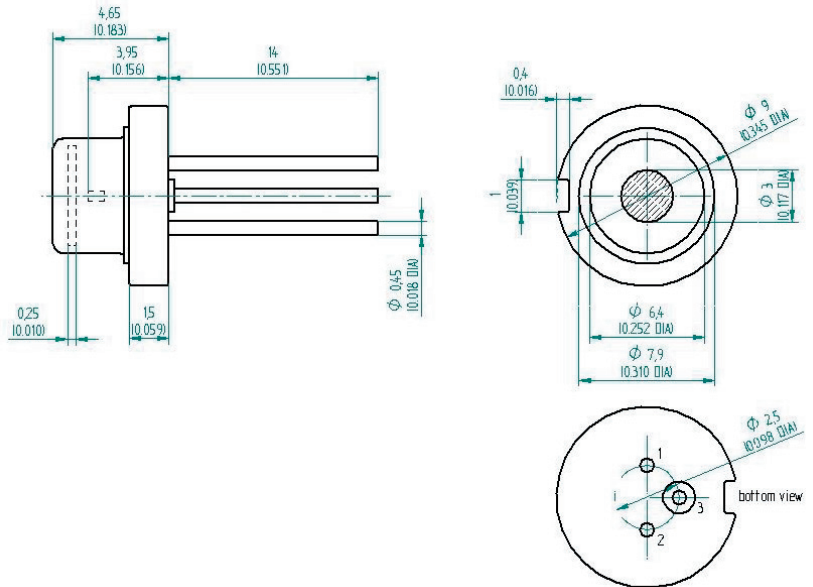
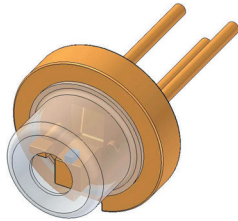

Package R: Pin Out: 1. LD Anode (+),  
2. NC,  
3. LD Cathode (-) Case, Inductance 6.8 nH

Package S TO-18

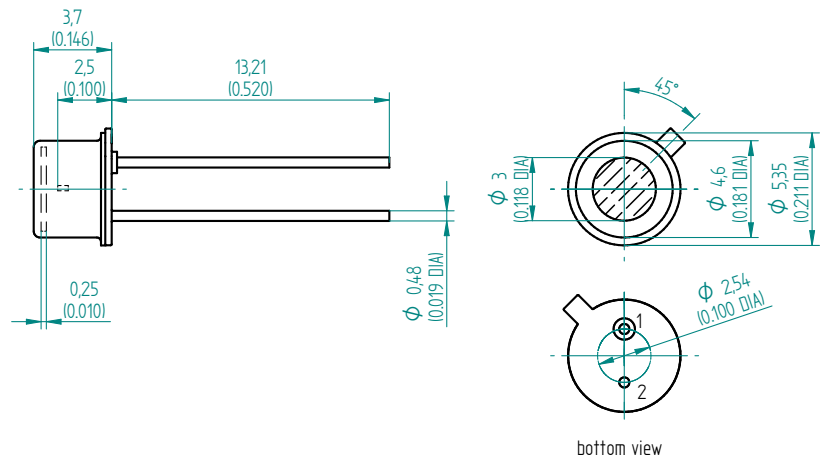
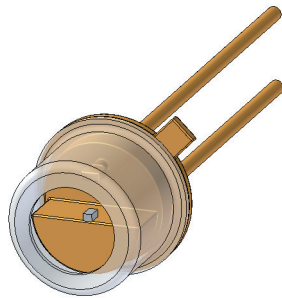

Package S: Pin Out: 1. LD Anode (+),  
2. LD Cathode (-) Case, Inductance 5.2 nH

Package U 5.6 mm CD

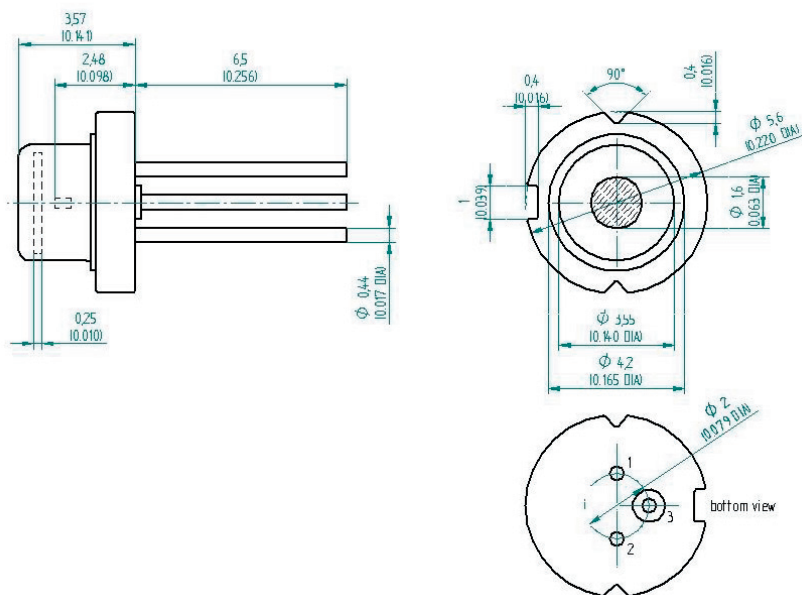
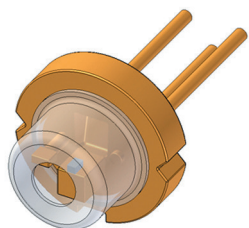

Package U: Pin Out: 1. LD Anode (+),  
2. NC,  
3. LD Cathode (-) Case, Inductance 5.0 nH

Package Y ceramic carrier

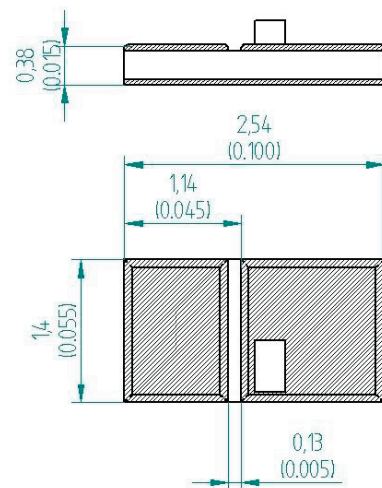
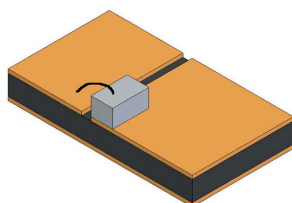

Package U: Pin Out: 1. LD Anode (+),  
2. LD Cathode (-) Case, Inductance 1.6 nH

## Product Changes

LASER COMPONENTS reserves the right to make changes to the product(s) or information contained herein without notice. No liability is assumed as a result of their use or application.

## Ordering Information

Products can be ordered directly from LASER COMPONENTS or its representatives. For a complete listing of representatives, visit our website at [www.lasercomponents.com](http://www.lasercomponents.com)

Custom designed products are available on request.

## Laser Safety

### Personal Hazard:

Depending on the mode of operation, these devices emit highly concentrated non visible infrared light which can be hazardous to the human eye. Products which incorporate these devices have to follow the safety precautions given in IEC 60825-1 "Safety of laser products".

### Handling Precautions:

Products are subject to the risks normally associated with sensitive electronic devices including static discharge, transients, and overload.

